



TEL 305.625.2451

ATLAS METAL

1135 N.W. 159th DRIVE, MIAMI, FLORIDA 33169

TOLL FREE 800.762.7565

FAX 305.623.0475

WIC/WICD/WICL/WICDL & WB/WSB Series

Service and Installation Manual

Please read this manual completely before attempting to install or operate this equipment!
Notify carrier of damage! Inspect all components immediately. See page 1.



WIC-ICED COLD PAN
4-5/8" STANDARD DEPTH



WB-ICE CHEST
NON-MECHANICAL



WICD-ICED COLD PAN
9-3/4" FULL DEPTH



WSB-WATER STATION
NON-MECHANICAL
WITH ICE CHEST



Effective Date: 04/24

**IMPORTANT INFORMATION
READ BEFORE USE**

CONTENTS

RECEIVING & INSPECTING EQUIPMENT.....	1
SERIAL AND MODEL# LOCATION.....	1
WIC, WICD, WICL, WICDL	
SPECIFICATIONS, FEATURES, ACCESSORIES, AND CUT OUTS.....	2-7
INSTALLATION, OPERATION AND S/S MAINTENANCE.....	8
PART LISTS.....	9
WB, WSB-SPECIFICATION, FEATURES, ACCESSORIES, AND CUT OUTS.....	10-13
INSTALLATION, OPERATION AND S/S MAINTENANCE.....	14
PART LISTS.....	15
LIMITED WARRANTY.....	16
WARRANTY INFORMATION.....	17

RECEIVING AND INSPECTING THE EQUIPMENT

1. VISUALLY INSPECT THE SHIPPING CRATE. DAMAGE SHOULD BE NOTED AND REPORTED TO THE DELIVERING CARRIER.
2. IF DAMAGED, OPEN AND INSPECT CONTENTS WITH CARRIER.
3. IF CRATE IS NOT DAMAGED AND THERE IS CONCEALED DAMAGE TO THE EQUIPMENT, NOTIFY THE CARRIER. NOTIFICATION MUST BE MADE VERBALLY AND IN WRITING.
4. REQUEST AN INSPECTION BY THE SHIPPING COMPANY FOR THE DAMAGED EQUIPMENT WITHIN 10 DAYS FROM RECEIPT OF THE EQUIPMENT
5. FREIGHT CARRIERS CAN SUPPLY THE NECESSARY FORMS ON REQUEST.
6. SAVE ALL CRATING MATERIALS UNTIL INSPECTION HAS BEEN MADE OR WAIVED.

SERIAL NUMBER LOCATION

Model # CAN BE FOUND ON THE UNIT OUTER ENCLOSURE - WHEN CALLING ATLAS FOR PARTS AND SERVICE ALWAYS HAVE HIS INFORMATION AVAILABLE.

MODEL #: _____

INSTALLATION DATE: _____



ATLAS METAL

1135 N.W. 159th DRIVE, MIAMI, FLORIDA 33169

TEL 305.625.2451

TOLL FREE 800.762.7565

FAX 305.623.0475

WWW.ATLASFOODSERV.COM

SALES@ATLASFOODSERV.COM

Project: _____
Item No.: _____
Quantity: _____

DROP-IN SERVING EQUIPMENT



WIC-3

COLD PAN

Iced Cold Pan
4-5/8" Standard Depth

- WIC-1
- WIC-2
- WIC-3
- WIC-4
- WIC-5
- WIC-6

SPECIFICATIONS

TOP: Constructed of 18 gauge, type 304 stainless steel, die stamped with a raised perimeter bead. There shall be a solid vinyl gasket under the beaded edge to form a seal to the counter top, thus preventing seepage or marring of the counter top. Embossed mounting lugs are provided along the inner surface of the top to hold the removable separator channels in place.

LINER: The inner liner shall be 18 gauge, type 304 stainless steel, one piece construction, all welded, ground and polished to a uniform finish. All corners are covered with a minimum 1/4" radius. A 3/4" dia. drain with strainer, 4" PVC nipple, and valve is provided.

INSULATION: The pan is fully insulated with high density polystyrene, 1" thick on all sides, 2" thick on the bottom, and enclosed with a 22 gauge galvanized steel outer case.

Specifications subject to change without notice.

STANDARD FEATURES

- Fully insulated to hold ice longer
- Factory applied gasket - makes installation a snap and seals units to the counter top, thus eliminating seepage
- Can be used for ice display, standard 12" x 20" pans with the use of separator channel(s), or fractional size pans with the use of optional adapter bars
- 1-Year Parts & Labor Warranty
- NSF Certified

ACCESSORIES

- Stainless Steel adapter bars (pg DI-51-52)
- Stainless Steel adapter plates (pg DI-51-52)
- **WFB** - Stainless steel perforated false bottom
- **CP** - Cover Plate with handles, S/S
- **RDVE** - Rear Drain Valve Extension

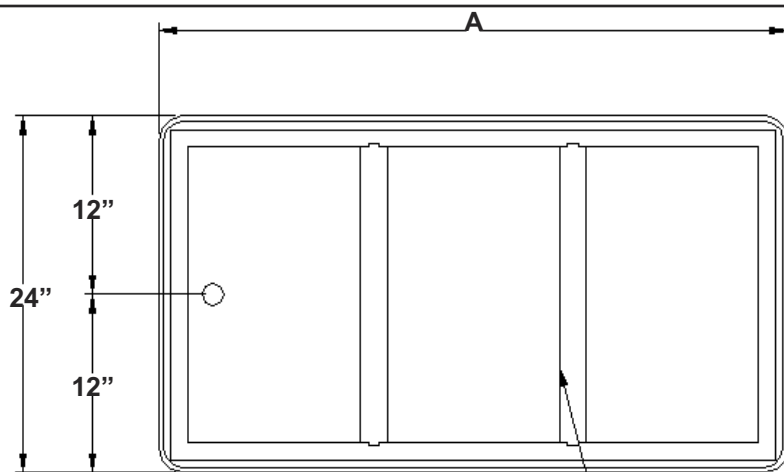

PLAN VIEW

REMOVABLE SEPARATOR CHANNELS

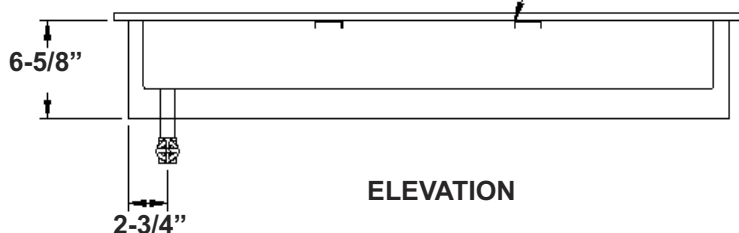

ELEVATION

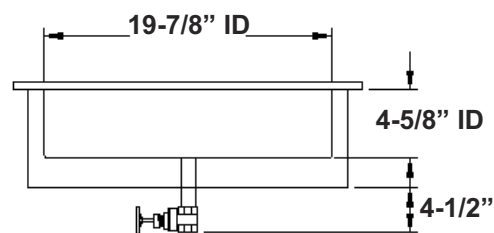

END VIEW

MODEL	PAN OPENINGS	"A"	PAN SIZE	CUT-OUT REQUIRED	SHIP WT. (LBS.)
WIC-1	1	16" (40.6cm)	19-7/8" X 11-3/4" X 4-5/8" (50.4 X 29.8 X 11.7cm)	22-1/4" X 14-1/4" (56.5 X 36.1cm)	28 (12.7kg)
WIC-2	2	29-3/4" (75.5cm)	19-7/8" X 25-1/2" X 4-5/8" (50.4 X 64.7 X 11.7cm)	22-1/4" X 28" (56.5 X 71.1cm)	42 (19kg)
WIC-3	3	43-1/2" (110.4cm)	19-7/8" X 39-1/4" X 4-5/8" (50.4 X 99.6 X 11.7cm)	22-1/4" X 41-3/4" (56.5 X 106cm)	69 (31.2kg)
WIC-4	4	57-1/4" (145.4cm)	19-7/8" X 53" X 4-5/8" (50.4 X 134.6 X 11.7cm)	22-1/4" X 55-1/2" (56.5 X 140.9cm)	122 (55.3kg)
WIC-5	5	71" (180.3cm)	19-7/8" X 66-3/4" X 4-5/8" (50.4 X 169.5 X 11.7cm)	22-1/4" X 69-1/4" (56.5 X 175.8cm)	130 (59kg)
WIC-6	6	84-3/4" (215.2cm)	19-7/8" X 80-1/2" X 4-5/8" (50.4 X 204.4 X 11.7cm)	22-1/4" X 83" (56.5 X 210.8cm)	115 (52.1kg)



ATLAS METAL

1135 N.W. 159th DRIVE, MIAMI, FLORIDA 33169

TEL 305.625.2451

TOLL FREE 800.762.7565

FAX 305.623.0475

WWW.ATLASFOODSERV.COM

SALES@ATLASFOODSERV.COM

Project: _____

Item No.: _____

Quantity: _____

DROP-IN SERVING EQUIPMENT



WICD-3

COLD PAN

Iced Cold Pan
9-3/4" Full Depth

- WICD-1
- WICD-2
- WICD-3
- WICD-4
- WICD-5
- WICD-6

SPECIFICATIONS

TOP: Constructed of 18 gauge, type 304 stainless steel, die stamped with a raised perimeter bead. There shall a solid vinyl gasket under the beaded edge to form a seal to the counter top, thus preventing seepage or marring of the counter top. Embossed mounting lugs are provided along the inner surface of the top to hold the removable separator channels in place.

LINER: The inner liner shall be 18 gauge, type 304 stainless steel, one piece construction, all welded, ground and polished to a uniform finish. All corners are covered with a minimum 1/4" radius. A 3/4" dia. drain with strainer, 4" PVC nipple, and valve is provided.

INSULATION: The pan is fully insulated with high density polystyrene, 1" thick on all sides, 2" thick on the bottom, and enclosed with a 22 gauge galvanized steel outer case.

Specifications subject to change without notice.

STANDARD FEATURES

- Accommodates your deepest pans or bowls - 9-3/4" deep
- Fully insulated to hold ice longer
- Factory applied gasket - makes installation a snap and seals units to the counter top, thus eliminating seepage
- Can be used for ice display, standard 12" x 20" X 6" pans with the use of separator channel(s), or fractional size pans with the use of optional adapter bars
- 1-Year Parts & Labor Warranty
- NSF Certified

ACCESSORIES

- Stainless Steel adapter bars (pg DI-51-52)
- Stainless Steel adapter plates (pg DI-51-52)
- WFB - Stainless steel perforated false bottom
- CP - Cover Plate with handles, S/S
- RDVE - Rear Drain Valve Extension

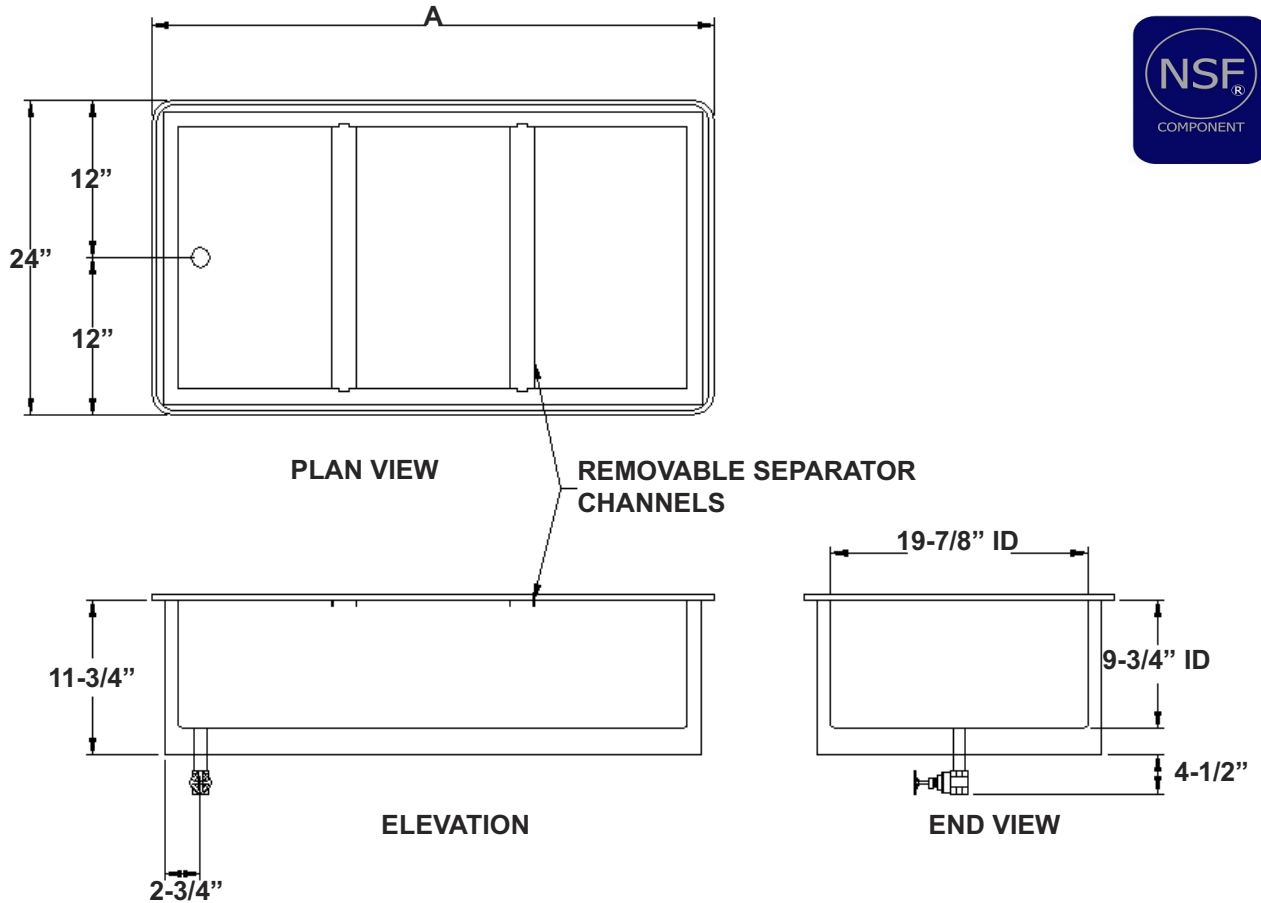

MODEL	PAN OPENINGS	"A"	PAN SIZE	CUT-OUT REQUIRED	SHIP WT. (LBS.)
WICD-1	1	16" (40.6cm)	19-7/8" X 11-3/4" X 9-3/4" (50.4 X 29.8 X 24.7cm)	22-1/4" X 14-1/4" (56.5 X 36.1cm)	54 (24.4kg)
WICD-2	2	29-3/4" (75.5cm)	19-7/8" X 25-1/2" X 9-3/4" (50.4 X 64.7 X 24.7cm)	22-1/4" X 28" (56.5 X 71.1cm)	68 (30.8kg)
WICD-3	3	43-1/2" (110.4cm)	19-7/8" X 39-1/4" X 9-3/4" (50.4 X 99.6 X 24.7cm)	22-1/4" X 41-3/4" (56.5 X 106cm)	110 (49.8kg)
WICD-4	4	57-1/4" (145.4cm)	19-7/8" X 53" X 9-3/4" (50.4 X 134.6 X 24.7cm)	22-1/4" X 55-1/2" (56.5 X 140.9cm)	152 (68.9kg)
WICD-5	5	71" (180.3cm)	19-7/8" X 66-3/4" X 9-3/4" (50.4 X 169.5 X 24.7cm)	22-1/4" X 69-1/4" (56.5 X 175.8cm)	184 (83.4kg)
WICD-6	6	84-3/4" (215.2cm)	19-7/8" X 80-1/2" X 9-3/4" (50.4 X 204.4 X 24.7cm)	22-1/4" X 83" (56.5 X 210.8cm)	205 (92.9kg)



ATLAS METAL

1135 N.W. 159th DRIVE, MIAMI, FLORIDA 33169

TEL 305.625.2451

TOLL FREE 800.762.7565

FAX 305.623.0475

WWW.ATLASFOODSERV.COM

SALES@ATLASFOODSERV.COM

Project: _____

Item No.: _____

Quantity: _____

SLIM-LINE SERVING EQUIPMENT

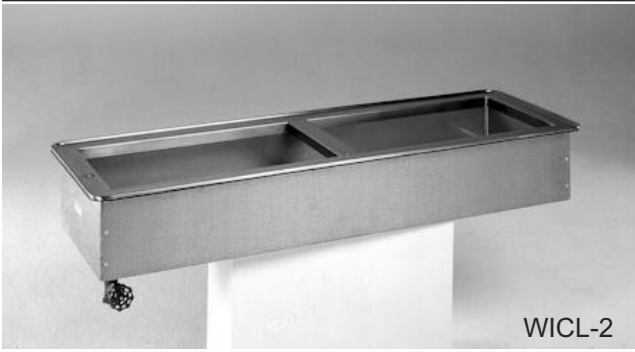

SLIM-LINE COLD PAN

Iced Cold Pan
4-5/8" Standard Depth
or 9-3/4" Full Depth

- WICL-2
- WICL-3
- WICL-4
- WICDL-2
- WICDL-3
- WICDL-4

SPECIFICATIONS

TOP: Constructed of 18 gauge, type 304 stainless steel, die stamped with a raised perimeter bead. There shall be a solid vinyl gasket under the beaded edge to form a seal to the counter top, thus preventing seepage or marring of the counter top. Embossed mounting lugs are provided along the inner surface of the top to hold a full set of removable separator channels in place.

LINER: The inner liner shall be 18 gauge, type 304 stainless steel, one piece construction, all welded, ground and polished to a uniform finish. All corners are covered with a minimum 1/4" radius. A 3/4" dia. drain with strainer, 4" PVC nipple, and valve is provided.

INSULATION: The pan is fully insulated with high density polystyrene, 1" thick on all sides, 2" thick on the bottom and enclosed with a 22 gauge galvanized steel outer case.

Specifications subject to change without notice.

STANDARD FEATURES

- Slim-line configuration - it can install in counters only 16" wide
- Fully insulated to hold ice longer
- Factory applied gasket - makes installation a snap and seals units to the counter top, thus eliminating seepage
- Can be used for ice display, standard 12" x 20" pans with the use of separator channel(s), or fractional size pans with the use of optional adapter bars
- 1-Year Parts & Labor Warranty
- NSF Certified

ACCESSORIES

- Stainless Steel adapter bars (pgs. DI-51-52)
- Stainless Steel adapter plates (pgs. DI-51-52)
- **WFBL** - Stainless steel perforated false bottom
- **CPL** - Cover Plate with handles, S/S
- **RDVE** - Rear Drain Valve Extension

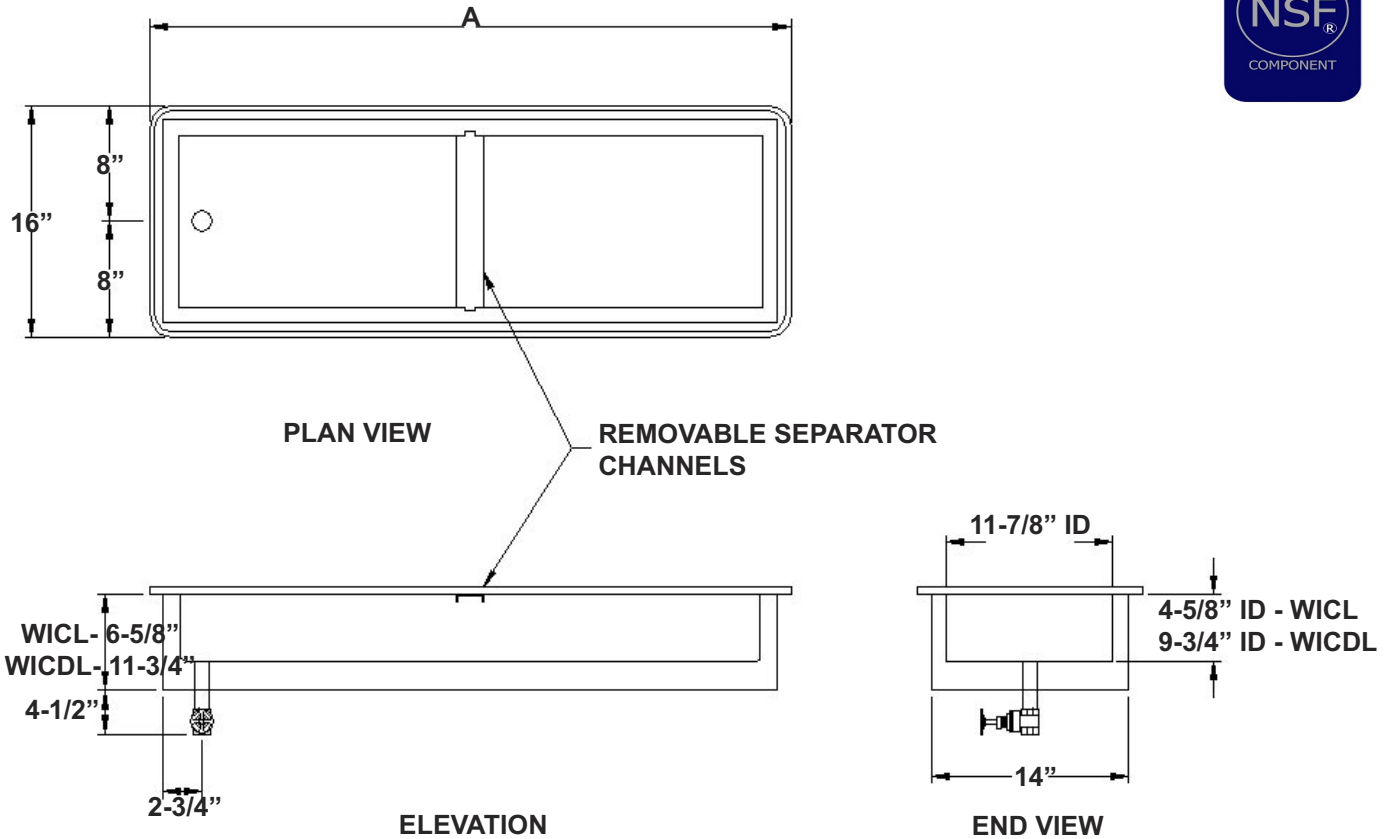

MODEL	PAN OPENING	PAN SIZE	CUT OUT REQUIRED	"A"	SHIP WT. (LBS.)
WICL-2 WICDL-2	2	11-7/8" X 41-3/4" X 4-5/8" (30.1 X 106 X 11.7cm)	14-1/4" X 44-1/4" (36.1 X 112.3cm)	46" (116.8cm)	45 (20.4kg) 48 (21.7kg)
WICL-3 WICDL-3	3	11-7/8" X 63-1/2" X 4-5/8" (30.1 X 161.2 X 11.7cm)	14-1/4" X 66" (36.1 X 167.6cm)	67-3/4" (172cm)	132 (59.8kg) 139 (63kg)
WICL-4 WICDL-4	4	11-7/8" X 85-1/4" X 4-5/8" (30.1 X 216.5 X 11.7cm)	14-1/4" X 87-3/4" (36.1 X 222.8cm)	89-1/2" (227.3cm)	150 (68kg) 158 (71.6kg)

ICE COLD PANS

WIC/ WICD / WICL/ AND WICDL SERIES

INSTALLATION

Provide the correct counter cut-out opening (see chart below) and drop in. The vinyl gasket assures complete seating. A non-toxic silicone seal may be used between the gasket and counter top (not required).

Note: Units are supplied with a nipple and stop valve to be connected for draining.

MODEL NUMBER	CUT-OUT OPENING
WIC & WICD-1	22 1/4 X 14 1/4
WIC & WICD-2	22 1/4 X 28
WIC & WICD-3	22 1/4 X 41 3/4
WIC & WICD-4	22 1/4 X 55 1/2
WIC & WICD-5	22 1/4 X 69 1/4
WIC & WICD-6	22 1/4 X 83
WICL & WICDL-2	14 1/4 X 44 1/4
WICL & WICDL-3	14 1/4 X 66
WICL & WICDL-4	14 1/4 X 87 3/4

OPERATION

The unit is ready to operate and should be level for draining purposes.

MAINTENANCE

NEVER CLEAN PANS WITH A CHLORIDE BASED PRODUCT. CHLORIDES OR IMPROPER CLEANING COULD SCAR, MARK AND/OR CORRODE PANS. **DO NOT** USE STEEL WOOL OR ABRASIVE PRODUCTS. TO CLEAN USE SOAPY WARM WATER, RINSE THOROUGHLY TO REMOVE ALL RESIDUES. **FAILURE TO MEET THESE CONDITIONS WILL VOID WARRANTY.**



ATLAS METAL

Subsidiary of Mercury Aircraft, Inc.

1135 N.W. 159th DR., MIAMI, FL 33169

PHONE (305) 625-2451, (800) 762-7565, FAX (305) 623-0475, E-mail: sales@atlasfoodserv.com

PARTS LIST FOR ICE COLD PANS WIC/ WICD / WICL/ AND WICDL SERIES

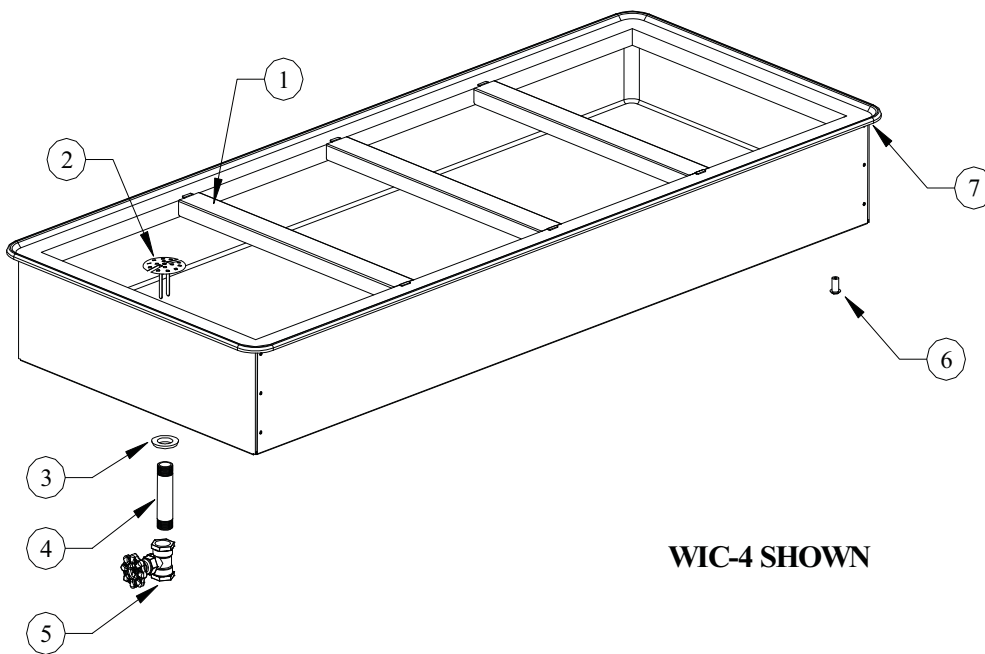

WIC-4 SHOWN

ITEM NUMBER	PART NUMBER	DESCRIPTION
1	S80103-000	Separator Channel (WIC, WICD)
1	S85008-000	Separator Channel (WICL, WICDL)
2	86-3202	Perforated Snap in Drain
3	49-1028	Grommet
4	30-3130	3/4 X 4 PVC Nipple
5	3016-2	Stop Valve
6	7020	Nylon Spacer
7	7002-0+Model #	Vinyl Bead Gasket



ATLAS METAL

1135 N.W. 159th DRIVE, MIAMI, FLORIDA 33169

TEL 305.625.2451

TOLL FREE 800.762.7565

FAX 305.623.0475

WWW.ATLASFOODSERV.COM

SALES@ATLASFOODSERV.COM

Project: _____

Item No.: _____

Quantity: _____

DROP-IN SERVING EQUIPMENT



WB-15

ICE CHEST

Non-Mechanical

WB-15

WB-19

SPECIFICATIONS

TOP: Constructed of 18 gauge, type 304 stainless steel, die stamped with a raised perimeter bead. There shall be a solid vinyl gasket under the beaded edge to form a seal to the counter top, thus preventing seepage or marring of the counter top.

ICE CHEST: The inner liner shall be 22 gauge, type 304 stainless. All corners are covered with a minimum 1/4" radius. A 3/4" dia. threaded drain fitting is provided.

INSULATION: The pan is fully insulated with high density polystyrene, 1" thick on all sides, 1-1/2" thick on the bottom and enclosed with a 24 gauge galvanized steel outer liner.

LID: The ice chest is provided with a S/S double pan, insulated lid with a rubber, self-insulating hinge. The entire lid is removable.

Specifications subject to change without notice.

STANDARD FEATURES

- Fully insulated to hold ice longer
- Removable S/S hinged lid
- Factory applied gasket - makes installation a snap and seals units to the counter top, thus eliminating seepage
- 1-Year Parts & Labor Warranty
- NSF Certified

*Please see Operation & Installation Manual for ALL operation and maintenance details.

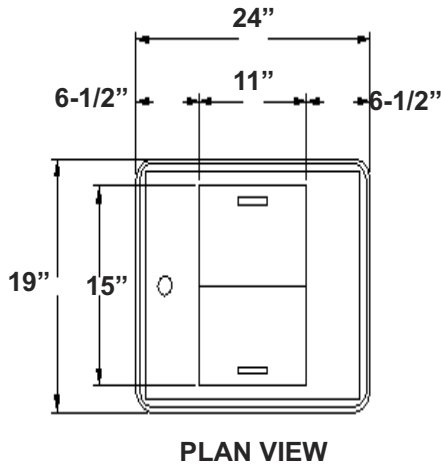

**WB-19
SHOWN**

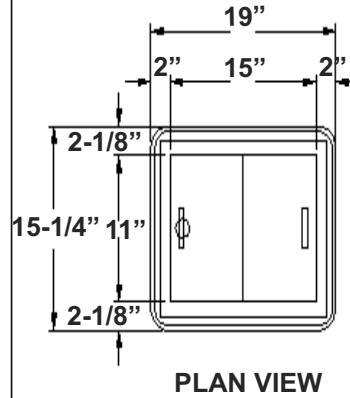

**WB-15
SHOWN**

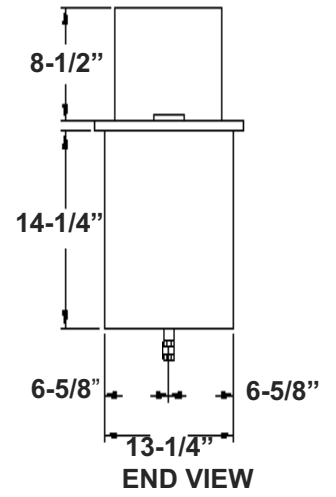
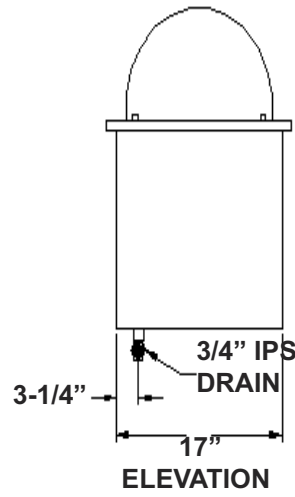
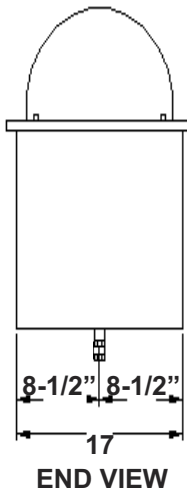
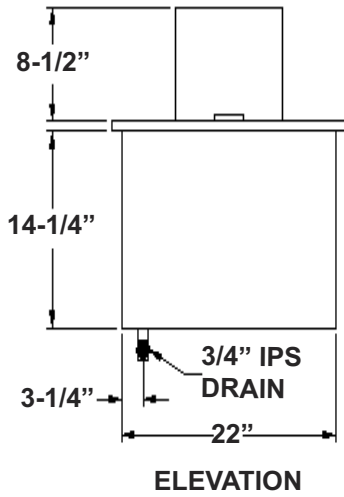

MODEL	CUT-OUT REQUIRED	ICE CAPACITY (LBS.)	SHIP WT (LBS.)
WB-15	13-1/2" X 17-1/4" (34.2 X 43.8cm)	40 (18.1kg)	34 (15.4kg)
WB-19	17-1/4" X 22-1/4" (43.8 X 56.5cm)	60 (27.2kg)	55 (24.9kg)



ATLAS METAL

1135 N.W. 159th DRIVE, MIAMI, FLORIDA 33169

TEL 305.625.2451

TOLL FREE 800.762.7565

FAX 305.623.0475

WWW.ATLASFOODSERV.COM

SALES@ATLASFOODSERV.COM

Project: _____

Item No.: _____

Quantity: _____

DROP-IN SERVING EQUIPMENT



WSB-15

WATER STATION

Non-Mechanical,
with Ice Chest

WSB-15

WSB-19

SPECIFICATIONS

TOP: Constructed of 18 gauge, type 304 stainless steel, die stamped with a raised perimeter bead. There shall be a solid vinyl gasket under the beaded edge to form a seal to the counter top, thus preventing seepage or marring of the counter top. A covered pan insert is secured to the top, and is equipped with a 1/4" IPS drain and a removable anti-splash grate. Mounted above the drain pan is a chrome plated, brass glass filler with a volume regulator and stream director.

ICE CHEST: The inner liner shall be 22 gauge, type 304 stainless steel. All corners are covered with a minimum 1/4" radius. A 1" plastic drain fitting is provided.

INSULATION: The pan is fully insulated with high density polystyrene, 1" thick on all sides, 1-1/2" thick on the bottom and enclosed with a 24 gauge galvanized steel outer liner.

LID: The ice chest is provided with a S/S double pan, insulated lid with a rubber, self-insulating hinge. The entire lid is removable.

Specifications subject to change without notice.

STANDARD FEATURES

- Chrome plated, lever action glass filler
- Large capacity ice chest - fully insulated to hold ice longer
- Removable S/S hinged lid
- Factory applied gasket - makes installation a snap and seals units to the counter top, thus eliminating seepage
- Sanitary - provided with a drain trough with anti-splash grate
- 1-Year Parts & Labor Warranty
- NSF Certified

ACCESSORIES

- 3020-2 - Pitcher Filler
- LLD - Lid Locking Device "Non-certified part"

*Please see Operation & Installation Manual for ALL operation and maintenance details.

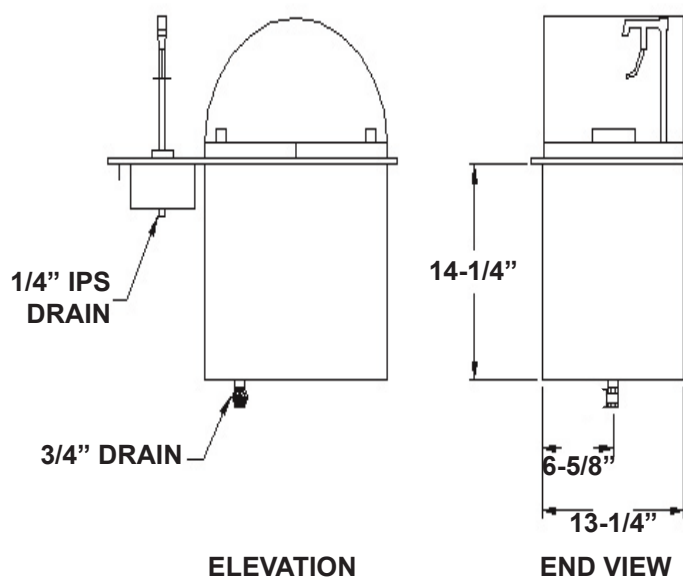
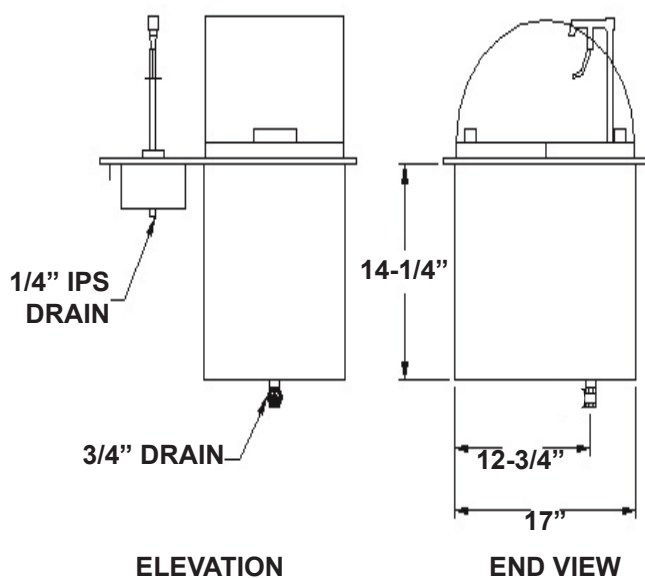
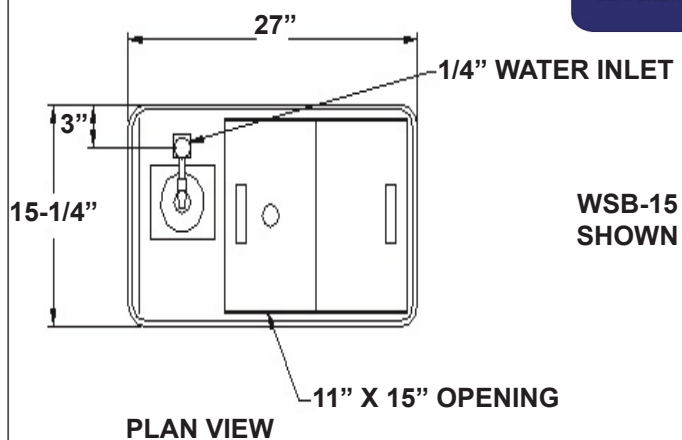
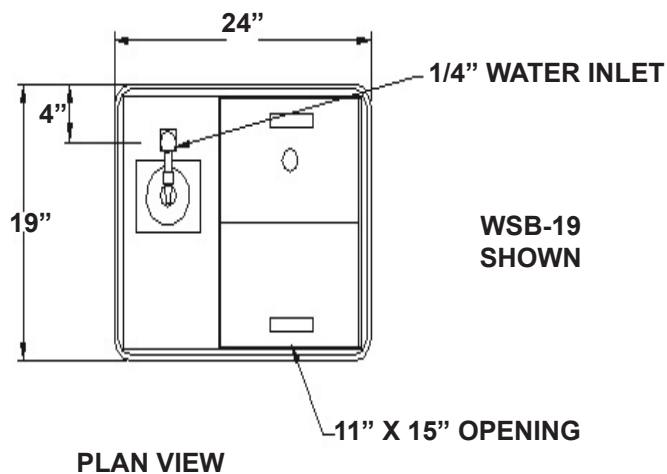

MODEL	CUT-OUT REQUIRED	ICE CAPACITY (LBS.)	SHIP WT (LBS.)
WSB-15	13-1/2" X 25-1/4" (34.2 X 64.1cm)	40 (18.1kg)	78 (35.4kg)
WSB-19	17-1/4" X 22-1/4" (43.8 X 56.5cm)	60 (27.2kg)	78 (35.4kg)

ICE CHEST & WATER STATIONS

WB & WSB SERIES

INSTALLATION

Provide the correct counter cut-out opening (see chart below) and drop in. The vinyl gasket assures complete seating. A non-toxic silicone seal may be used between the gasket and counter top (not required).

MODEL NUMBER	CUT-OUT SIZE
WB-15	13 1/2 X 17 1/4
WB-19	17 1/4 X 22 1/4
WSB-15	13 1/2 X 25 1/4
WSB-19	17 1/4 X 22 1/4

NOTE: Units are supplied with a 1" I.P.S. Drain to be connected for draining and cleaning purposes.

OPERATION

The unit is ready to operate and should be level for draining purposes.

MAINTENANCE

NEVER CLEAN PANS WITH A CHLORIDE BASED PRODUCT. CHLORIDES OR IMPROPER CLEANING COULD SCAR, MARK AND/OR CORRODE PANS. **DO NOT** USE STEEL WOOL OR ABRASIVE PRODUCTS. TO CLEAN USE SOAPY WARM WATER, RINSE THOROUGHLY TO REMOVE ALL RESIDUES. **FAILURE TO MEET THESE CONDITIONS WILL VOID WARRANTY.**



ATLAS METAL

Subsidiary of Mercury Aircraft, Inc.

1135 N.W. 159th DR., MIAMI, FL 33169

PHONE (305) 625-2451, (800) 762-7565, FAX (305) 623-0475, E-mail: sales@atlasfoodserv.com

PARTS LIST ICE CHEST & WATER STATIONS WB & WSB SERIES

WB SERIES

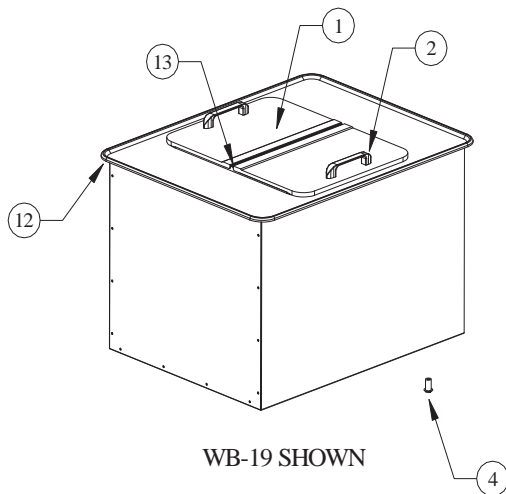

WSB SERIES

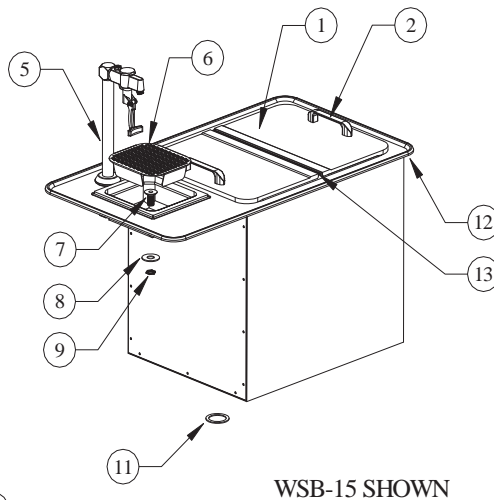

ITEM NUMBER	PART NUMBER	DESCRIPTION
1	S81854-000	Lid Assembly
2	6043	Lid Handle
3	4043	Handle Screws (Not Shown)
4	7020	Nylon Spacer
5	3020	Faucet
6	S81806-000	Strainer
7	3019	1" Plastic Drain
8	3100	1" Washer
9	4200	1" Nut
10	1012-0902	1" PVC Drain nipple (Not Shown)
11	49-1029	1" Rubber Grommet
12	7002-0+Model #	Vinyl Bead Gasket
13	S81809-000	Plastic Hinge
14	7030	Plastic Underlid (Not Shown)
15	3020	Picher and glass filler (Not Shown)



A T L A S M E T A L

LIMITED WARRANTY

Atlas Metal Industries, Inc. warrants to the Purchaser of this product that the same shall be free from defects in the workmanship and material for a period of one year from the date of original installation of the equipment, but not to exceed eighteen (18) months after date of shipment from factory. During this period of time Atlas Metal Industries, Inc. will replace all defective parts and will pay for authorized replacement labor. Replacement and installation of such parts and labor shall be provided only upon prior written authority of Atlas Metal Industries, Inc.

The Refrigeration warranty is for a twenty (20) month time period and includes supplying the compressor at a no charge basis provided the damage to the compressor was not caused by the customer or end user. Authorized replacement labor will be paid for a period of one year from date of installation. Freight costs for defective unit to and from Atlas Metal Industries, Inc. are not included, and all defective parts must be returned to the factory freight prepaid for evaluation. **ALL WARRANTY LABOR MUST BE AUTHORIZED BY ATLAS METAL INDUSTRIES, INC. PRIOR TO THE ACTUAL WORK BEING DONE.** This warranty does not apply to any equipment or any part thereof, which has been subjected to shipping damage, improper voltage, alteration, abuse or misuses, and does not cover loss of food, other products, or damage to property due to mechanical or electrical malfunction.

THERE ARE NO WARRANTIES WHICH EXTEND BEYOND THE DESCRIPTION OF THE FACE HEREOF. SELLER DISCLAIMS ANY IMPLIED WARRANTY OF MERCHANTABILITY OF THE GOODS OR THE FITNESS OF THE GOODS FOR ANY PURPOSE AND BUYER AGREES THAT THE GOODS ARE SOLD "AS IS."



A T L A S M E T A L

WARRANTY INFORMATION

In order to have your invoice approved for payment by the factory, please note the following:

An authorization number must be obtained from the factory prior to performing any warranty service.

Atlas Metal will not approve excessive labor due to poor access to the unit being serviced. If design does not allow reasonable access, contact the factory.

All travel time that exceeds 100 miles round trip must be authorized by the factory.

**Thank You:
Warranty service Dept.**