



ATLAS METAL

1135 N.W. 159th DRIVE, MIAMI, FLORIDA 33169

TEL 305.625.2451

TOLL FREE 800.762.7565

FAX 305.623.0475

WWW.ATLASFOODSERV.COM

SALES@ATLASFOODSERV.COM

Project: _____

Item No.: _____

Quantity: _____

SLIM-LINE DROP-IN SERVING EQUIPMENT

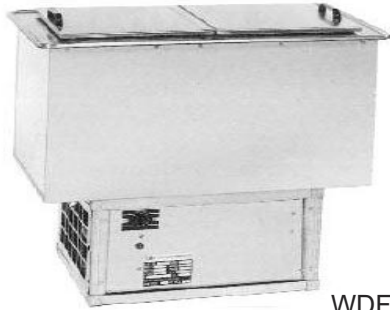

WDF-L

SLIM-LINE ICE CREAM FREEZER

WDF-L

Refrigerated,
Self-Contained

SPECIFICATIONS

TOP: Constructed of 18 gauge, type 304 stainless steel, die stamped with a raised perimeter bead. There shall be a solid vinyl gasket under the beaded edge to form a seal to the counter top, thus preventing seepage or marring of the counter top.

LINER: The inner liner shall be 18 gauge, type 304 stainless steel, one piece construction, all welded, ground and polished to a uniform finish. All corners are covered with a minimum 1/4" radius on the horizontal edges and a minimum 3/4" radius on the vertical edges. The liner has copper tubing firmly soldered to the exterior sides and bottom. The unit is provided with an all stainless steel, insulated, hinged, lift off lid, with plastic coated pulls.

INSULATION: The unit is fully insulated with high density polystyrene, 2-1/2" thick on all sides, and enclosed with a 22 gauge galvanized steel outer liner.

REFRIGERATION SYSTEM: The compressor housing shall be fabricated from formed angles and bolted to the base of the unit. A fully self-contained condensing unit is provided with a hermetically sealed compressor and a thermostat control. The system is fully charged with CFC free refrigerant and ready to operate.

NOTE: Proper ventilation must be provided in counter.

ELECTRICAL: The unit will be wired for 15 amps., 120 volt, single phase operation, with an on/off thermostat switch and pilot light. A 6' long, 3-wire cord and plug (NEMA 5-15P) will be provided.

Specifications subject to change without notice.

STANDARD FEATURES

- Slim-line configuration - it can install in counters only 16-1/2" wide
- Fully insulated for maximum efficiency and energy savings
- Removable S/S hinged lid
- Factory applied gasket - makes installation a snap and seals units to the counter top, thus eliminating seepage
- Ideal for any frozen dessert or use it as a mug or plate chiller
- 1-Year Parts & Labor Warranty
- NSF Certified and UL Listed

ACCESSORIES

- **5YW** - 5-Year Compressor Warranty
- Hinged Plexiglas Lid
- **LLD** - Lid Locking Device
- **2060-1** - Condensate Evaporator
- **RS** - Remote On/Off Switch for counter mounting
- * **220 Volt - 50 Cycle** Compressor

*Please see Operation & Installation Manual for ALL operation and maintenance details.

* Units with these accessories are not currently UL listed.

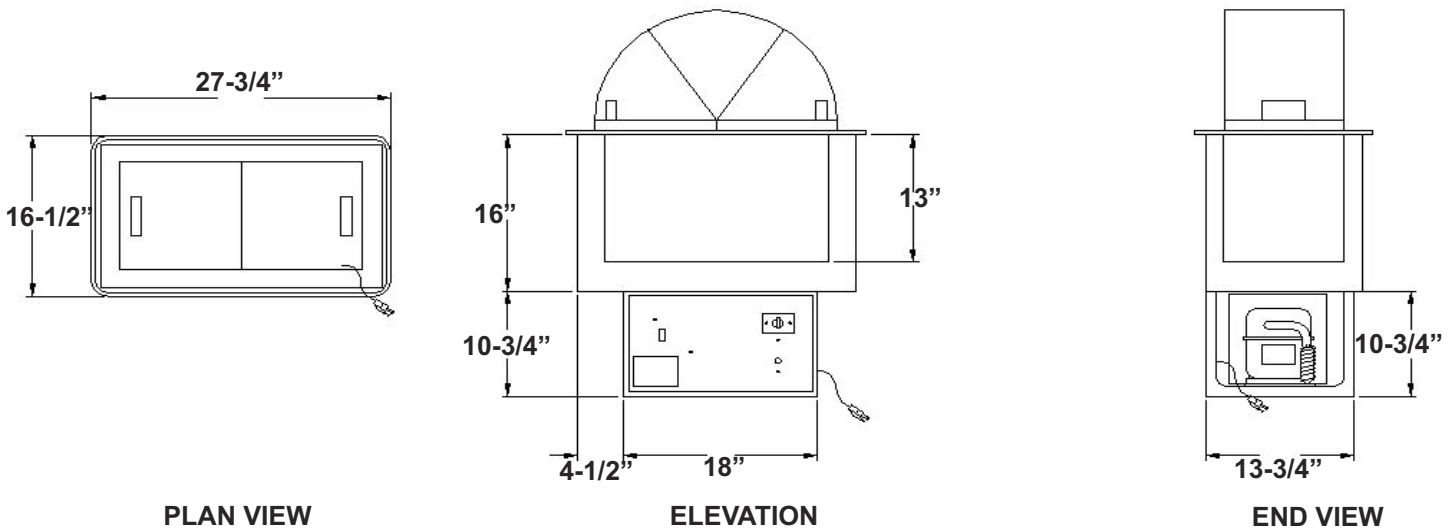

MODEL	SIZE W x L x D	CU. FT. CAPACITY	LBS. CAPACITY	ELECTRICAL CHARACTERISTICS	CUT-OUT REQUIRED	SHIP WT. (LBS.)
WDF-L	22-1/2" X 11-1/4" X 13" (57.2 X 28.6 X 33cm)	1.9	65 (29.5kg)	2.4 amps. - 120V 1/5 HP	26" X 15" (66 X 38.1cm)	158 (54kg)

REFRIGERATION CHART						
MODEL	HP	REF.	OZ.	LOW PSIG.	HIGH PSIG.	BTU M10 90A
WDF-L	1/5	134A	2.5	min 3 in	129	505

WDF-LX - REFRIGERATED ICE CREAM FREEZER WITHOUT COMPRESSOR
Units include Refrigerated Ice Cream Freezer, Thermostat, Cap Tube & Drier (for hook up in field by others)

COMPRESSORS FOR REMOTE INSTALLATIONS
2029 - 1/5 HP for WDF-LX