



**ATLAS METAL**

Subsidiary of Mercury Aircraft, Inc.

1135 N.W. 159th DR., MIAMI, FL 33169

PHONE (305) 625-2451, (800) 762-7565, FAX (305) 623-0475, E-mail: [sales@atlasfoodserv.com](mailto:sales@atlasfoodserv.com)

## PARTS LIST REFRIGERATED PASS THROUGH DISPLAY CASE WCPT SERIES

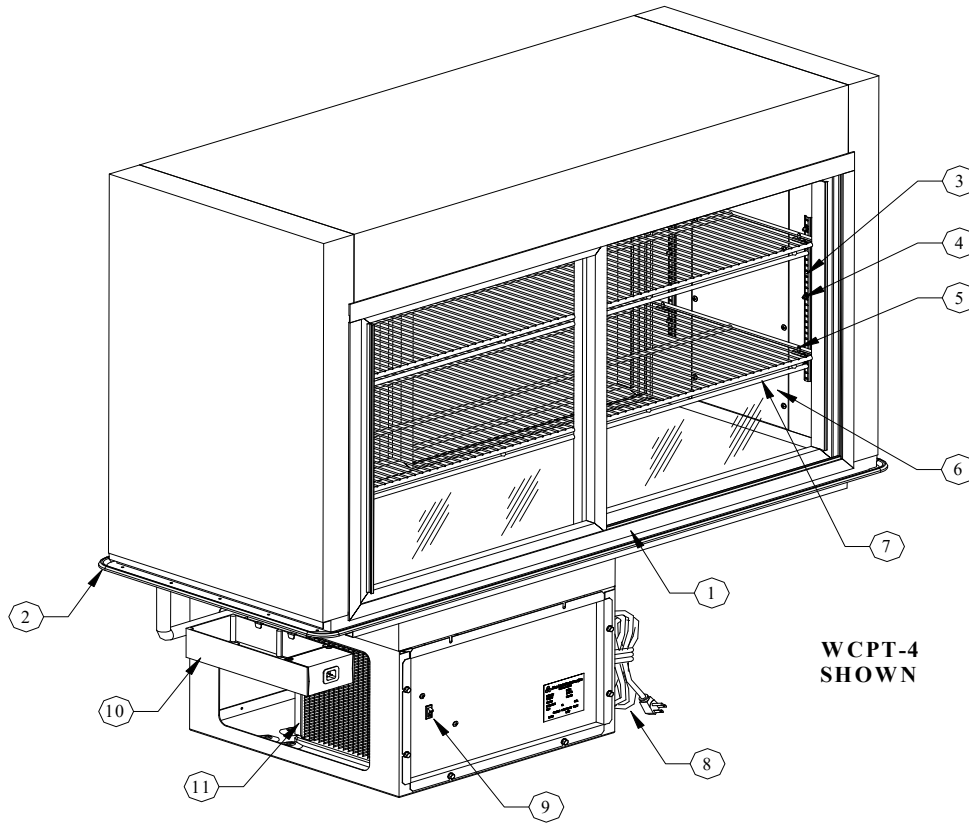

**WCPT-4  
SHOWN**

ITEM NUMBER	PART NUMBER	DESCRIPTION
1	27-15	Door Set #3
	27-20	Door Set #4
2	7002-0+Model #	Vinyl Bead Gasket
3	6151-5	Pilaster
4	6151-2	Thumbscrew
5	6151-1	Snap-In Shelf Supports
6	81-7990	Plexiglass Light Cover (White)
7	27-17	Wire Shelf #3
	27-16	Wire Shelf #4
8	1003-0	Power Cord
9	1069-1	Compressor Switch
10	2060-1	Condensing Water Evaporator
11	1800-4212	1/2 H.P. Compressor
12	2013-0	Fan Motor (Not Shown)
13	S81441-0	Fan Guard (Not Shown)
14	2014-5	Fan Blade (Not Shown)
15	600010	Expansion Valve

ITEM NUMBER	PART NUMBER	DESCRIPTION
16	2119-0	Evaporator Coil #3 (Not Shown)
		Evaporator Coil #4 (Not Shown)
17	113-10	Thermometer (Not Shown)
18	7019-2	Bulb Holder (Not Shown)
19	27-125	Light Switch (Not Shown)
20	1034-1	Ballast (Not Shown)
21	60-6056	Door Lock (Optional)
22	27-108	Mirror Door #3 (Optional)
23	27-107	Mirror Door #4 (Optional)
24	27-123	Door Spring #3 (Not Shown)
	27-122	Door Spring #4 (Not Shown)
	27-124	Door Seal (Not Shown)
25	22-2040	Low Pressure Control (Not Shown)
26	22-2036	Bracket (Not Shown)
27	2024	Drier (Not Shown)
	680-63	Door Roller
	1149	Fan Motor Wire Harness

# REFRIGERATED PASS THROUGH DISPLAY CASE

## WCPT SERIES

---

---

### INSTALLATION

Provide the correct counter cut-out opening (see chart below) and drop unit in. The vinyl gasket assures complete seating. A non-toxic silicone sealer may be used between the gasket and counter top (not required).

MODEL	CUT-OUT REQUIRED
WCPT-3	22 1/4" X 41 3/4"
WCPT-4	22 1/4" X 55 1/2"

The unit should be level for draining purposes. When installing unit in counter, it is recommended that the operator side of the counter be completely open for air circulation. When this is not possible, such as in an island counter, it is recommended that two grill openings are provided approximately 18" x 18" of free air for intake and exhaust at the opposite ends of counter. Also the counter must have an opening of approximately 24" x 14" to access the compressor for maintenance. Then the refrigeration components can be reached by removing six (6) screws from control and rear panels.

The unit is supplied with a power cord and NEMA plug. Refer to data plate on compressor housing for the amperage and voltage information. Use a licensed electrician when installing power source.

For cleaning and maintenance of inside top evaporator coil a qualified refrigeration technician is recommended.

---

---

### OPERATION

The unit is ready to be operated as soon as it is plugged in and switched on. The unit has been pre-tested for proper operation from 35 to 40 degrees.

---

---

### MAINTENANCE

**NEVER** CLEAN THE UNIT WITH A CHLORIDE BASED PRODUCT. CHLORIDES OR IMPROPER CLEANING COULD SCAR, MARK AND/OR CORRODE METAL. **DO NOT** USE STEEL WOOL OR ABRASIVE PRODUCTS. TO CLEAN USE SOAPY WARM WATER, RINSE THOROUGHLY TO REMOVE ALL RESIDUES. CLEAN CONDENSER COIL REGULARLY.

**FAILURE TO MEET THESE CONDITIONS WILL VOID WARRANTY.**