



# ATLAS METAL

1135 N.W. 159th DRIVE, MIAMI, FLORIDA 33169

TEL 305.625.2451

TOLL FREE 800.762.7565

FAX 305.623.0475

WWW.ATLASFOODSERV.COM

SALES@ATLASFOODSERV.COM

Project: \_\_\_\_\_

Item No.: \_\_\_\_\_

Quantity: \_\_\_\_\_

## SLIM-LINE DROP-IN SERVING EQUIPMENT



WCMDCL-2

### SLIM-LINE COLD PAN

Refrigerated  
Self-Contained  
9-3/4" Full Depth

- WCMDCL-2
- WCMDCL-3
- WCMDCL-4

### SPECIFICATIONS

**TOP:** Constructed of 18 gauge, type 304 stainless steel, die stamped with a raised perimeter bead. There shall be a solid vinyl gasket under the beaded edge to form a seal to the counter top, thus preventing seepage or marring of the counter top. Embossed mounting lugs are provided along the inner surface of the top to hold a full set of removable separator channels in place.

**LINER:** The inner liner shall be 18 gauge, type 304 stainless steel, one piece construction, all welded, ground and polished to a uniform finish. All corners are covered with a minimum 1/4" radius. The liner has copper tubing firmly soldered to the exterior **BOTTOM AND ALL SIDES**. 4" dia. drain with strainer, 4" PVC nipple, and valve is provided.

**INSULATION:** The pan is fully insulated with high density polystyrene, 1" thick on all sides, 1-1/2" thick on the bottom and enclosed with a 22 gauge galvanized steel outer case.

**REFRIGERATION SYSTEM:** The compressor housing shall be fabricated from 14 gauge galvanized angles and bolted to the base of the unit. A fully self-contained condensing unit is provided, with a hermetically sealed compressor and a thermostat control. The system is fully charged with CFC free refrigerant and ready to operate.

**NOTE:** Proper ventilation must be provided in counter

**ELECTRICAL:** The unit will be wired for 15 amps., 120 volt, single phase operation, with an on/off thermostat switch and pilot light. A 6' long, 3-wire cord and plug (NEMA 5-15P) will be provided.

*Specifications subject to change without notice.*

### STANDARD FEATURES

- Slim-line configuration - it can install in counters only 16" wide
- Accommodates your deepest pan or insert - 9-3/4" deep
- The unit have refrigerated copper tubing around all sides and base - meets your toughest health department standards
- Fully insulated for maximum efficiency and energy savings
- Factory applied gasket - makes installation a snap and seals units to the counter top, thus eliminating seepage
- Accommodates standard 12" X 20" pans with the use of separator channel(s), or fractional size pans with the use of optional adapter bars.
- 1-Year Parts & Labor Warranty
- NSF Certified and UL Listed

### ACCESSORIES

- **5YW** - 5-Year Compressor Warranty
- **WFBL** - Stainless steel perforated false bottom
- Stainless Steel adapter bars (pg DI-51-52)
- Stainless Steel adapter plates (pg DI-51-52)
- **CPL** - Cover Plate with handles, S/S
- **2060-1** - Condensate Evaporator
- **RS** - Remote on/off switch for counter mounting
- **RDVE** - Rear Drain Valve Extension
- \* **220 Volt - 50 Cycle** Compressor

*These units have not been performance tested for use with potentially hazardous foods, and must be used with ice.*

\*Please see Operation & Installation Manual for ALL operation and maintenance details.

\* Units with these accessories are not currently UL listed.

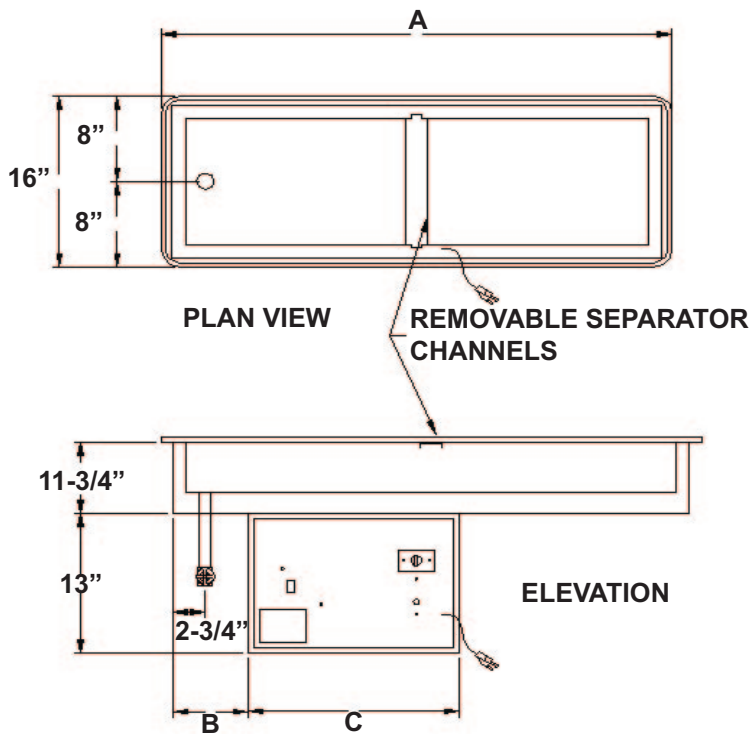

MODEL	OPENING	"A"	"B"	"C"	"D"	PAN SIZE	ELECTRICAL CHARACTERISTICS	CUT-OUT REQUIRED	SHIP WT. (LBS.)
WCMDCL-2	2	46" (116.8cm)	6-3/8" (16.1cm)	18" (45.7cm)	13-3/4" (34.9cm)	11-7/8" X 41-3/4" X 9-3/4" (30.1 X 106 X 24.7cm)	3.9 amps. - 120V - 1/5HP	14-1/4" x 44-1/4" (36.1 X 112.3cm)	179 (81.1kg)
WCMDCL-3	3	67-3/4" (172cm)	6-3/8" (16.1cm)	18" (45.7cm)	13-3/4" (34.9cm)	11-7/8" X 63-1/2" X 9-3/4" (30.1 X 161.2 X 24.7cm)	3.9 amps. - 120V - 1/5HP	14-1/4" X 66" (36.1 X 167.6cm)	232 (105.2kg)
WCMDCL-4	4	89-1/2" (227.3cm)	6-3/4" (17.1cm)	21-3/4" (53.34cm)	13-7/8" (33.02cm)	11-7/8" X 85-1/4" X 9-3/4" (30.1 X 216.5 X 24.7cm)	6.8 amps. - 120V - 1/4HP	14-1/4" X 87-3/4" (36.1 X 222.8cm)	278 (126kg)

REMOTE REFRIGERATION MODEL	LESS COMP. SHIP WT. (LBS.)
WCMDCLX-2	138 (62.6kg)
WCMDCLX-3	148 (67.1kg)
WCMDCLX-4	231 (104.8kg)

### WCMDCLX - REFRIGERATED COLD PAN WITHOUT COMPRESSOR

Units include Refrigerated Cold Pan, Thermostat, Cap Tube & Drier (for hook up in field by others)

### COMPRESSORS FOR REMOTE INSTALLATIONS

**2029** - 1/5 HP for WCMDCLX -2 & 3  
**2029-17JP** - 1/4 HP for WCMDCLX - 4