



ATLAS METAL

1135 N.W. 159th DRIVE, MIAMI, FLORIDA 33169

TEL 305.625.2451

TOLL FREE 800.762.7565

FAX 305.623.0475

WWW.ATLASFOODSERV.COM

SALES@ATLASFOODSERV.COM

Project: _____

Item No.: _____

Quantity: _____

DROP-IN SERVING EQUIPMENT



COLD PAN

Refrigerated
Air Flow System
Self-Contained with
Defrost System

- WCM-BT-3
- WCM-BT-4
- WCM-BT-5
- WCM-BT-6

WCM-BT-4

SPECIFICATIONS

TOP: Constructed of 18 gauge, type 304 stainless steel, die stamped with a raised perimeter bead. There shall be a solid vinyl gasket under the beaded edge to form a seal to the counter top, thus preventing seepage or marring of the counter top. Embossed mounting lugs are provided along the inner surface of the top to hold a full set of removable separator channels in place.

LINER: The inner liner shall be 18 gauge, type 304 stainless steel, one piece construction, all welded, ground and polished to a uniform finish. All corners are covered with a minimum 1/4" radius.

INSULATION: The pan is fully insulated with high density polystyrene, 1" thick on all sides, 2" thick on the bottom and enclosed with a 22 gauge galvanized steel outer case.

REFRIGERATION SYSTEM: The compressor housing shall be fabricated from 14 gauge galvanized and bolted to the base of the unit. A fully self-contained condensing unit is provided with a hermetically sealed compressor and a thermostat control. The system is also provided with a forced air evaporator for even temperature throughout the pan that drains into a condensate evaporator pre-wired in the unit. Automatic defrost system is provided. The system is fully charged with CFC free refrigerant and ready to operate.

NOTE: Proper ventilation must be provided in counter.

ELECTRICAL: The unit will be wired for 15 amps., 120 volt, single phase operation with an on/off thermostat switch and pilot light. A 6' long, 3-wire cord and plug (NEMA 5-15P) will be provided.

Specifications subject to change without notice.

STANDARD FEATURES

- Forced air evaporator blower system for maximum efficiency in cooling - more consistent food product temperature
- Automatic Defrost System
- Fully insulated for maximum efficiency and energy savings
- Factory applied gasket - makes installation a snap and seals units to the counter top, thus eliminating seepage
- Accommodates standard 12" X 20" pans with the use of separator channel(s), or fractional size pans with the use of optional adapter bars
- 1-Year Parts & Labor Warranty
- UL Listed

ACCESSORIES

- **5YW** - 5-Year Compressor Warranty
- Stainless Steel adapter bars (pg DI-51-52)
- Stainless Steel adapter plates (pg DI-51-52)
- **CP** - Cover Plate with handles, S/S
- **RS** - Remote on/off switch for counter mounting
- * **220 Volt - 50 Cycle** Compressor

*Please see Operation & Installation Manual for ALL operation and maintenance details.

* Units with these accessories are not currently UL listed.

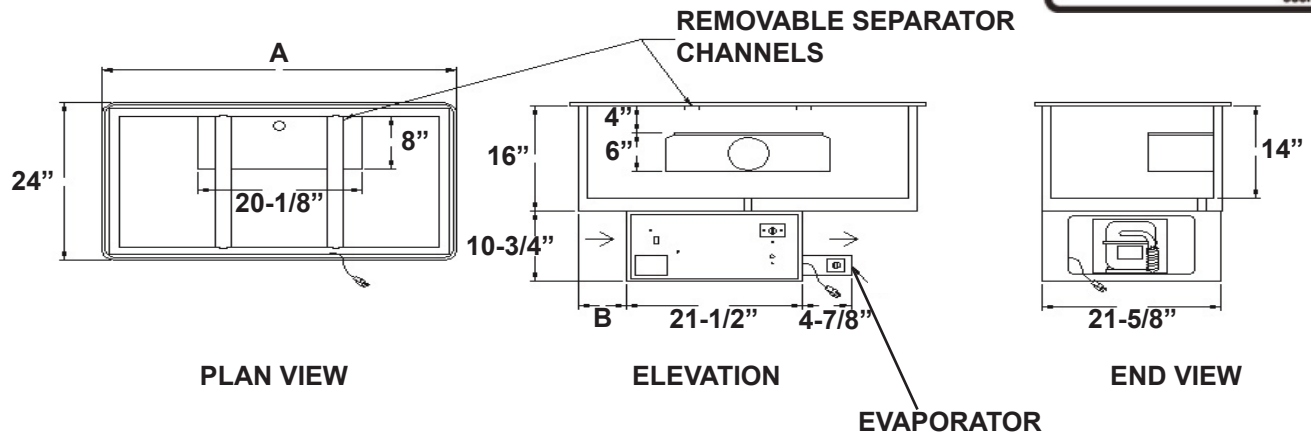

MODEL	PAN OPENINGS	PAN SIZE	"A"	"B"	CUT-OUT REQUIRED	ELECTRICAL CHARACTERISTICS	SHIP WT. (LBS.)
WCM-BT-3	3	19-7/8" X 39-1/4" X 14" (50.4 X 99.6 X 35.5cm)	43-1/2" (110.4cm)	6" (15.24cm)	22-1/4" X 41-3/4" (56.5 X 106cm)	6.2 amps. - 120V - 1/4HP	228 (103.4kg)
WCM-BT-4	4	19-7/8" X 53" X 14" (50.4 X 134.6 X 35.5cm)	57-1/4" (145.4cm)	4-1/8" (10.5cm)	22-1/4" X 55-1/2" (56.5 X 140.9cm)	6.5 amps. - 120V - 1/3HP	268 (121.5kg)
WCM-BT-5	5	19-7/8" X 66-3/4" X 14" (50.4 X 169.5 X 35.5cm)	71" (180.3cm)	7" (17.78cm)	22-1/4" X 69-1/4" (56.5 X 175.8cm)	6.5 amps. - 120V - 1/3HP	311 (141.1kg)
WCM-BT-6	6	19-7/8" X 80-1/2" X 14" (50.4 X 204.4 X 35.5cm)	84-3/4" (215.2cm)	7" (17.78cm)	22-1/4" X 83" (56.5 X 210.8cm)	6.5 amps. - 120V - 1/3HP	345 (156.4kg)

REMOTE REFRIGERATION MODEL	LESS COMP. SHIP WT. (LBS.)
WCM-BT-X-3	180 (81.6kg)
WCM-BT-X-4	222 (100.6kg)
WCM-BT-X-5	259 (117.4kg)
WCM-BT-X-6	299 (135.6kg)

REFRIGERATION CHART							
MODEL	HP	REF.	OZ.	LOW PSIG.	HIGH PSIG.	BTU M10 90A	OPERATING TEMP
WCM-BT-3	1/4	R513A	9	12	155	720	32 TO 40 F
WCM-BT-4	1/3	R513A	10	12	155	850	32 TO 40 F
WCM-BT-5	1/3	R513A	10	12	155	850	32 TO 40 F
WCM-BT-6	1/3	R513A	10	12	155	850	32 TO 40 F

REFRIGERATED COLD PAN WITHOUT COMPRESSOR REQUIRED:

SOLENOID PACKAGE, LOOSE: SOLENOID VALVE, SOLENOID COIL & COOPER FITTING
 SOLENOID PACKAGE, FACTORY INSTALLED: SOLENOID BOX, SOLENOID VALVE, COIL & COOPER FITTING
 ****ORDERS NOT FINAL UNTIL REFRIGERANT APPROVED****

COMPRESSORS FOR REMOTE INSTALLATIONS

2029-2M7 - 1/4 HP for WCM-BT-X-3
2029-4M7 - 1/3 HP for WCM-BT-X-4, 5 & 6

NOTEWCM-BT-X
 REQUIRED A SOLENOID
 PACKAGE