



ATLAS METAL

1135 N.W. 159th DRIVE, MIAMI, FLORIDA 33169

TEL 305.625.2451

TOLL FREE 800.762.7565

FAX 305.623.0475

WWW.ATLASFOODSERV.COM

SALES@ATLASFOODSERV.COM

Project: _____

Item No.: _____

Quantity: _____

DROP-IN SERVING EQUIPMENT



RM-4

COLD PAN
(3" Recessed Top)
Refrigerated
with Side Coils
Self-Contained

- RM-1
- RM-2
- RM-3
- RM-4
- RM-5
- RM-6

SPECIFICATIONS

TOP: Constructed of 18 gauge, type 304 stainless steel, die stamped with a raised perimeter bead. There shall be a solid vinyl gasket under the beaded edge to form a seal to the counter top, thus preventing seepage or marring of the counter top. Embossed mounting lugs are provided along the inner surface, 3" down from the top, to hold the pan rails and a full set of removable separator channels in place.

LINER: The inner liner shall be 18 gauge, type 304 stainless steel with a 3" recessed top, one piece construction, all welded, ground and polished to a uniform finish. All corners are covered with a minimum 1/4" radius. The liner has copper tubing firmly soldered to the top 3" on all sides. A 3/4 dia. drain with strainer, 4" PVC nipple, and valve is provided.

INSULATION: The pan is fully insulated with high density polystyrene, 1" thick on all sides, 2" thick on the bottom and enclosed with a 22 gauge galvanized steel outer case.

REFRIGERATION SYSTEM: The compressor housing shall be fabricated from 14 gauge galvanized and bolted to the base of the unit. A fully self-contained condensing unit is provided with a hermetically sealed compressor and digital electronic thermostat/thermometer. The system is fully charged with CFC free refrigerant and ready to operate.

NOTE: Proper ventilation must be provided in the counter.

ELECTRICAL: The unit will be wired for 15 amps., 120 volt, single phase operation with an on/off switch and pilot light. A 6' long, 3-wire cord and plug (NEMA 5-15P) will be provided.

Specifications subject to change without notice.

STANDARD FEATURES

- Refrigerated copper tubing, within the 3" recess, around all sides - meets your toughest health department standards
- Fully insulated for maximum efficiency and energy savings
- Factory applied gasket - makes installation a snap and seals units to the counter top, thus eliminating seepage
- Accommodates standard 12" X 20" pans with the use of separator channel(s) and pan rails, or fractional size pans with the use of optional adapter bars
- 1-Year Parts & Labor Warranty
- NSF Certified; UL Listed

ACCESSORIES

- **5YW** - 5-Year Compressor Warranty
- **WFB** - Stainless steel perforated false bottom
- Stainless Steel adapter bars (pg DI-51-52)
- Stainless Steel adapter plates (pg DI-51-52)
- **CP** - Cover Plate with handles, S/S
- **2060-1** - Condensate Evaporator
- **RS** - Remote on/off switch for counter mounting
- **RDVE** - Rear Drain Valve Extension
- * **220 Volt - 50 Cycle** Compressor

*Please see Operation & Installation Manual for ALL operation and maintenance details.

* Units with these accessories are not currently UL listed.

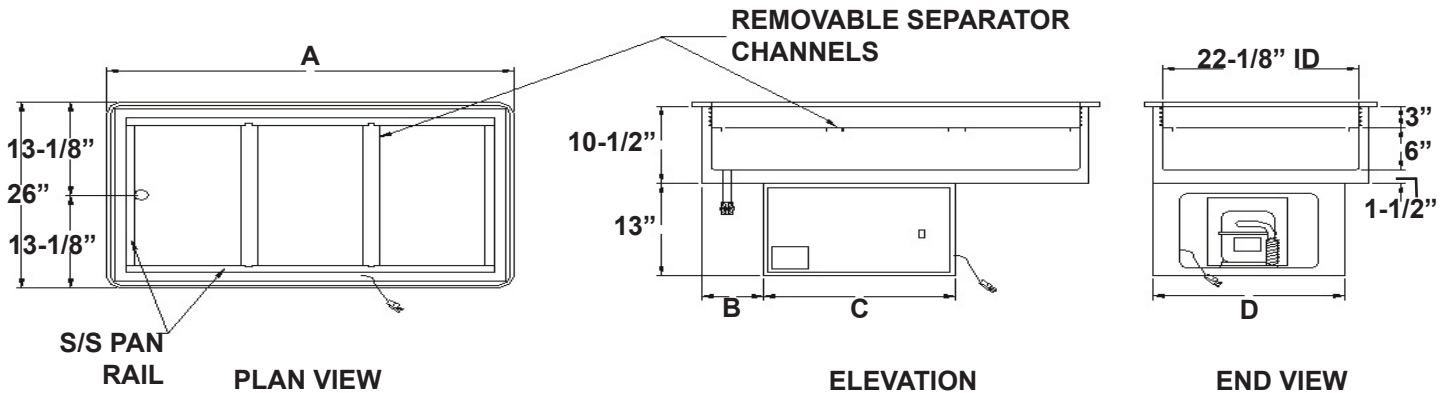

| MODEL | PAN OPENINGS | PAN SIZE | "A" | "B" | "C" | "D" | CUT-OUT REQUIRED | ELECTRICAL CHARACTERISTICS | SHIP WT. (LBS.) |
|-------|--------------|---|----------------------|----------------|---------------------|---------------------|---------------------------------------|----------------------------|------------------|
| RM-1 | 1 | 19-7/8" X 11-7/8" X 9" (50.4 X 30.1 X 22.8cm) | 18-1/8" (46.3cm) | 6" (15.2cm) | 18" (45.7cm) | 13-3/4" (34.9cm) | 24-1/2" X 16-1/2" (62.2 X 41.9cm) | 4.2 amps. - 120V - 1/5HP | 148 (67.1kg) |
| RM-2 | 2 | 19-7/8" X 25-5/8" X 9" (50.4 X 65 X 22.8cm) | 31-3/4" (81.2cm) | 7" (17.7cm) | 21-1/2" (54.6cm) | 21-5/8" (54.9cm) | 24-1/2" X 30-1/4" (62.2 X 76.8cm) | 6.2 amps. - 120V - 1/4HP | 203 (92kg) |
| RM-3 | 3 | 19-7/8" X 39-3/8" X 9" (50.4 X 99.9 X 22.8cm) | 45-1/2" (116.2cm) | 7" (17.7cm) | 21-1/2" (54.6cm) | 21-5/8" (54.9cm) | 24-1/2" X 44" (62.2 X 111.7cm) | 6.2 amps. - 120V - 1/4HP | 244 (110.6kg) |
| RM-4 | 4 | 19-7/8" X 53-1/8" X 9" (50.4 X 134.9 X 22.8cm) | 59-1/8" (151.1cm) | 7" (17.7cm) | 21-1/2" (54.6cm) | 21-5/8" (54.9cm) | 24-1/2" X 57-3/4" (62.2 X 146.6cm) | 6.5 amps. - 120V - 1/3HP | 274 (124.3kg) |
| RM-5 | 5 | 19-7/8" X 66-7/8" X 9" (50.4 X 169.8 X 22.8cm) | 73" (186cm) | 7" (17.7cm) | 21-1/2" (54.6cm) | 21-5/8" (54.9cm) | 24-1/2" X 71-1/2" (62.2 X 181.6cm) | 10.7 amps. - 120V - 1/2HP | 341 (154.6kg) |
| RM-6 | 6 | 19-7/8" X 80-5/8" X 9" (50.4 X 204.7 X 22.8cm) | 86-3/4" (220.9cm) | 7" (17.7cm) | 21-1/2" (54.6cm) | 21-5/8" (54.9cm) | 24-1/2" X 85-1/4" (62.2 X 216.5cm) | 10.7 amps. - 120V - 1/2HP | 389 (176.4kg) |

| REMOTE REFRIGERATION MODEL | RMX LESS COMP. WT. (LBS.) |
|----------------------------|---------------------------|
| RMX-1 | 85 (38.5kg) |
| RMX-2 | 140 (63.5kg) |
| RMX-3 | 185 (83.9kg) |
| RMX-4 | 215 (97.5kg) |
| RMX-5 | 240 (108.8kg) |
| RMX-6 | 300 (136kg) |

| REFRIGERATION CHART | | | | | | | |
|---------------------|-----|-------|-----|-----------|------------|-------------|------------------------------------|
| MODEL | HP | REF. | OZ. | LOW PSIG. | HIGH PSIG. | BTU M10 90A | TEMPERATURE SETTING / DIFFERENTIAL |
| RM-1 | 1/5 | R513A | 12 | 8 | 175 | 450 | 18 OFF / 8DIFF (26 ON) |
| RM-2 | 1/4 | R448A | 17 | 30 | 275 | 624 | 15 OFF / 6DIFF (21 ON) |
| RM-3 | 1/4 | R448A | 19 | 30 | 275 | 624 | 15 OFF / 6DIFF (21 ON) |
| RM-4 | 1/3 | R448A | 22 | 35 | 300 | 865 | 18 OFF / 8DIFF (26 ON) |
| RM-5 | 3/4 | R448A | 27 | 35 | 300 | N/A | 18 OFF / 8DIFF (26 ON) |
| RM-6 | 3/4 | R448A | 30 | 15 | 275 | N/A | -2 OFF / 7 DIFF (5 ON) |

REFRIGERATED COLD PAN WITHOUT COMPRESSOR REQUIRED:

SOLENOID PACKAGE, LOOSE: SOLENOID VALVE, SOLENOID COIL & COOPER FITTING

SOLENOID PACKAGE, FACTORY INSTALLED: SOLENOID BOX, SOLENOID VALVE, COIL & COOPER FITTING

COMPRESSORS FOR REMOTE INSTALLATIONS

- 2029-1M7 - 1/5 HP for RMX-1
- 2029-11M6 - 1/4 HP for RMX-2 & 3
- 2029-16M6 - 3/4 HP for RMX-4
- 2029-13M6 - 3/4 HP for RMX-5 & 6