



# ATLAS METAL

Subsidiary of Mercury Aircraft, Inc.

1135 N.W. 159th DR., MIAMI, FL 33169

PHONE (305) 625-2451, (800) 762-7565, FAX (305) 623-0475, E-mail: [sales@atlasfoodserv.com](mailto:sales@atlasfoodserv.com)

## PARTS LIST FOR RECESSED MECHANICAL COLD PANS RM & RML SERIES

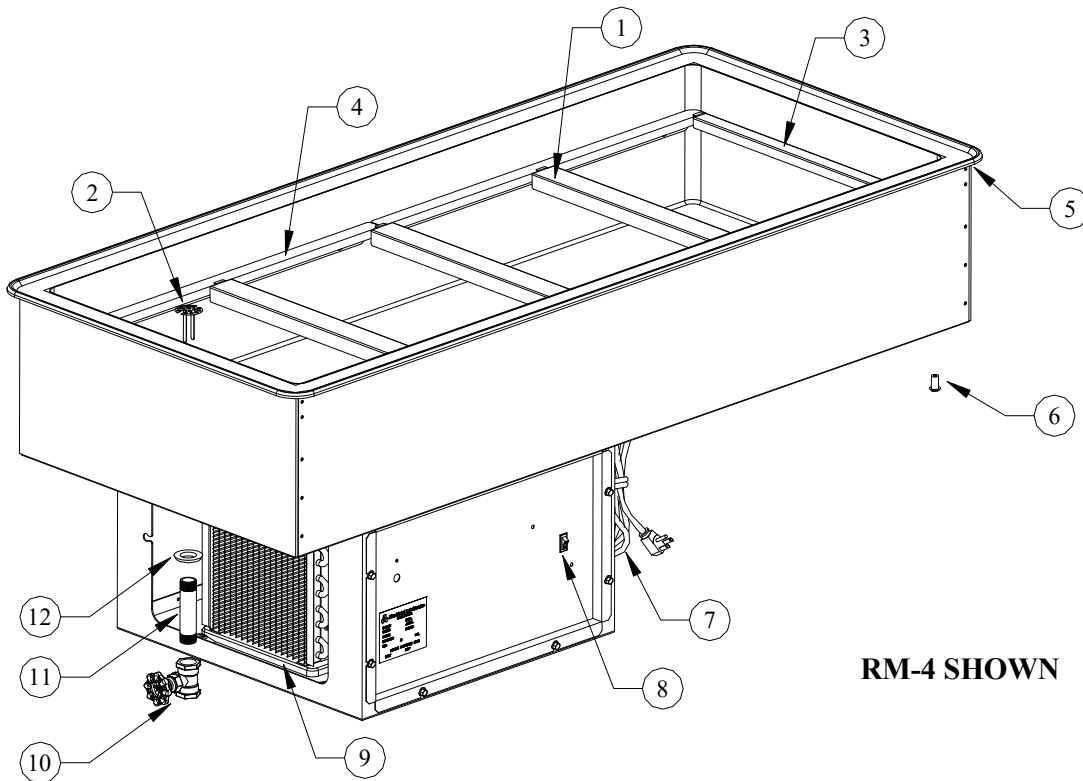

**RM-4 SHOWN**

ITEM NUMBER	PART NUMBER	DESCRIPTION
1	S80103-0	Separator Channel (RM)
	S85008-0	Separator Channel (RML)
2	86-3202	Perforated Snap- In Drain
3	S83432-0	Pan Rail End RM'S (2 Req'd)
	S83442-0	Pan Rail Ends for RM-1, RML, (2 Req'd)
4	S83438-0	Pan Rail Sides for RM-1 (2 Req'd)
	S83440-0	Pan Rail Sides for RM-2 (2 Req'd)
		Pan Rail Sides for RM-4 (4 Req'd)
		Pan Rail Sides for RM-6 (6 Req'd)
	S83439-0	Pan Rail Sides for RM-3 (2 Req'd)
	S83441-0	Pan Rail Sides for RM-5 (4 Req'd)
	S83443-0	<b>Pan Rail Sides for RML Only</b>
Pan Rail Sides for RML-2 (4 Req'd)		
Pan Rail Sides for RML-3 (6 Req'd)		
Pan Rail Sides for RML-4 (8 Req'd)		

ITEM NUMBER	PART NUMBER	DESCRIPTION
5	7002-0+Model #	Vinyl Bead Gasket
6	7020-0	Nylon Spacer
7	1003-0	Power Cord with Plug RM-1,2,3,4
	1002-7	Power Cord with Plug RM-5,6
8	1069-1	Switch with Light
9	2029-0	1/5 H.P. Compressor
	2029-5	1/4 H.P. Compressor
	2029-6	1/3 H.P. Compressor
	2029-7	1/2 H.P. Compressor
10	3016-2	Stop Valve
11	30-3130	PVC Nipple
12	49-1028	Grommet
13	22-1397	Thermostat (Not Shown)
14	2024-2	Drier (Not Shown)
15	2027-0	0.031 Cap Tube (for 1/5 H.P) Comp. (Not Shown)
16	494-54(not shown)	1/4 Expansion Valve RM-4-5-6
17	494-53(not shown)	1/8 Expansion Valve RM-2-3

# RECESSED MECHANICAL COLD PANS

## RM & RML SERIES

---

### INSTALLATION

Provide the correct counter cut-out opening (see chart below) and drop in. The vinyl gasket assures complete seating. A non-toxic silicone seal may be used between the gasket and counter top (not required).

Note: Units are supplied with a nipple and gate valve to be connected for draining.

MODEL NUMBER	CUT-OUT SIZE
RM-1	24 1/2 X 16 1/2
RM-2	24 1/2 X 30 1/4
RM-3	24 1/2 X 44
RM-4	24 1/2 X 57 3/4
RM-5	24 1/2 X 71 1/2
RM-6	24 1/2 X 85 1/4
RML-2	16 1/2 X 46 1/2
RML-3	16 1/2 X 68 1/4
RML-4	16 1/2 X 90

---

The unit should be level for draining purposes. When installing unit in a counter, it is recommended that the operator side of the counter be completely open for air circulation. When this is not possible, such as in an island counter, it is recommended that two grill openings are provided approximately 18" x 18" of free air for intake and exhaust at the opposite ends of the counter. Also the counter must have an opening of approximately 24" x 14" to access the compressor for maintenance. Then the compressor can be reached by removing four (4) screws from the control and rear panels.

The unit is supplied with a power cord and NEMA plug. Refer to the data plate on the compressor housing for the amperage and voltage information. Use a licensed electrician when installing power source.

---

Note: see TABLE# 1 for BTU/HR and evaporator temperatures.

---

### OPERATION

This unit should be turned on one hour before serving and turned off after completing the serving period. The thermostat has been pre-set at the factory.

All food products must be 34-35 degrees when placed in the unit. Food products must be 3 inches below the top of the unit. **Note: The unit should not operate 24/7.**

---

### MAINTENANCE

**NEVER** CLEAN PANS WITH A CHLORIDE BASED PRODUCT. CHLORIDES OR IMPROPER CLEANING COULD SCAR, MARK AND/OR CORRODE PANS. **DO NOT** USE STEEL WOOL OR ABRASIVE PRODUCTS. TO CLEAN USE SOAPY WARM WATER, RINSE THOROUGHLY TO REMOVE ALL RESIDUES. **FAILURE TO MEET THESE CONDITIONS WILL VOID WARRANTY.**  
**CLEAN CONDENSER COIL REGULARLY.**