



ATLAS METAL

1135 N.W. 159th DRIVE, MIAMI, FLORIDA 33169

TEL 305.625.2451

TOLL FREE 800.762.7565

FAX 305.623.0475

WWW.ATLASFOODSERV.COM

SALES@ATLASFOODSERV.COM

Project: _____

Item No.: _____

Quantity: _____

DROP-IN SERVING EQUIPMENT



RM-HP-2

HOT/COLD PAN

(3" Recessed Top)

Dual Temp.

Hot or Cold Service

(For Hot Mode)

Water Must Be Used

RM-HP-1

RM-HP-2

RM-HP-3

RM-HP-4

RM-HP-5

RM-HP-6

SPECIFICATIONS

TOP: Constructed of 18 gauge, type 304 stainless steel, die stamped with a raised perimeter bead. There shall be a solid vinyl gasket under the beaded edge to form a seal to the counter top, thus preventing seepage or marring of the counter top. Embossed mounting lugs are provided along the inner surface, 3" down from the top, to hold the pan rails and a full set of removable separator channels in place.

LINER: The inner liner shall be 18 gauge, type 304 stainless steel, one piece construction, all welded, ground and polished to a uniform finish. All corners are covered with a minimum 1/4" radius. The liner has copper tubing firmly soldered to the top 3" on all sides. A 3/4" dia. drain with strainer, 4" copper nipple, and valve is provided.

INSULATION: The pan is fully insulated with high density fiberglass, 1-3/8" thick on all sides, 1-1/2" thick on the bottom and enclosed with a 22 gauge galvanized steel outer case.

HEATING ELEMENT: An immersion type heating element is provided in the bottom of the pan along with a perforated stainless steel sheath cover. A thermostat control is included. **Please note: the element must be submerged in water to operate properly.**

REFRIGERATION SYSTEM: The compressor housing shall be fabricated from galvanized formed angles and bolted to the base of the unit. A fully self-contained condensing unit is provided with a hermetically sealed compressor and a thermostat control. The system is fully charged with CFC free refrigerant and ready to operate.

NOTE: Proper ventilation must be provided in counter

ELECTRICAL: The unit is pre-wired with a hot/cold selector switch that prevents dual operation, with the required thermostat controls and pilot light. The unit is provided with a 6' long, 3-wire cord and a twist lock plug.

Specifications subject to change without notice.

STANDARD FEATURES

- Dual Temp. - a hot serving unit becomes a refrigerated cold pan at the flip of a switch
- Fully insulated for maximum efficiency and energy savings
- Factory applied gasket - makes installation a snap and seals units to the counter top, thus eliminating seepage
- Accommodates standard 12" X 20" pans with the use of separator channel(s) and pan rails, or fractional size pans with the use of optional adapter bars
- 1-Year Parts & Labor Warranty
- NSF Certified and UL Listed

ACCESSORIES

- **5YW** - 5-Year Compressor Warranty
- Stainless Steel adapter bars (pgs. DI-51-52)
- Stainless Steel adapter plates (pgs. DI-51-52)
- **CP** - Cover Plate with handles, S/S
- **RSHP** - Remote Switch for counter mounting
- **RDVE** - Rear Drain Valve Extension
- **AF** - Automatic water fill
- * **220 Volt - 50 Cycle Compressor**

*Please see Operation & Installation Manual for ALL operation and maintenance details.

* Units with these accessories are not currently UL listed.

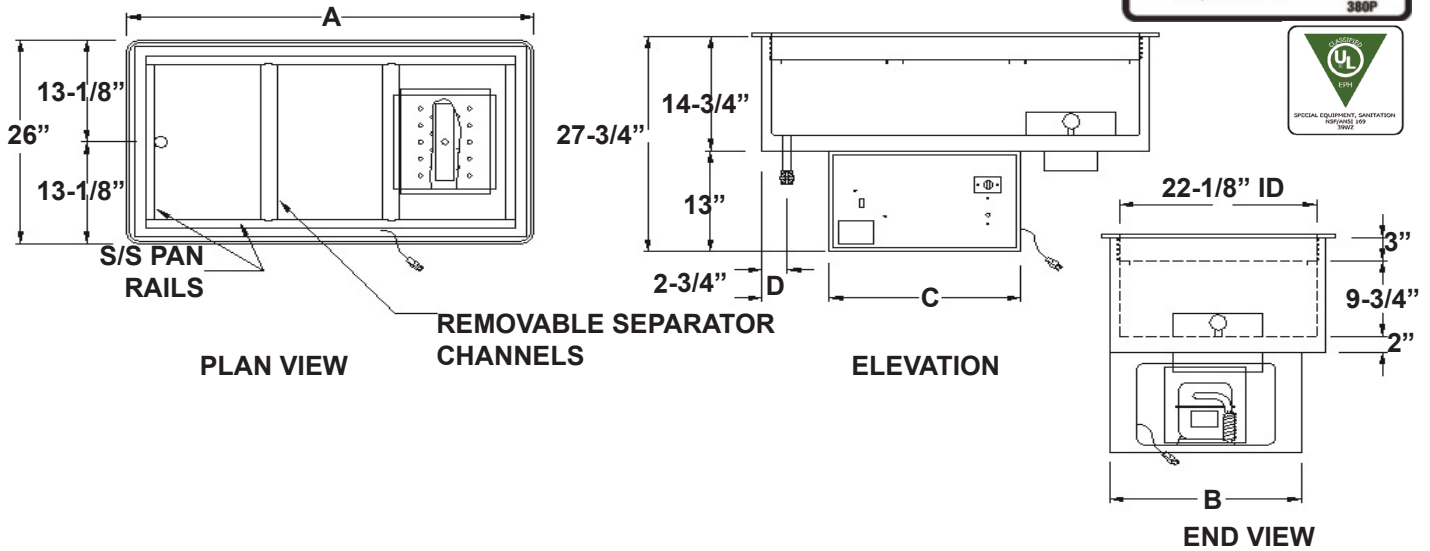

MODEL	PAN OPENINGS	PAN SIZE	"A"	"B"	"C"	"D"	COUNTER CUT-OUT REQUIRED	ELECTRICAL CHARACTERISTICS		SHIP WT. (LBS.)
								HOT OPERATION	COLD OPERATION	
RM-HP-1	1	19-7/8" X 11-7/8" X 9" (50.4 X 30.1 X 22.8cm)	18-1/8" (46.3cm)	18" (45.7cm)	13-3/4" (34.9cm)	1-3/4" (4.4cm)	24-1/2" X 16-1/2" (62.2 X 41.9cm)	16.7 amps. - 2KW - 120V	4.2 amps. - 120V - 1/5 HP	145 (65.8kg)
RM-HP-2	2	19-7/8" X 25-5/8" X 12-1/4" (50.4 X 65.6 X 31.1cm)	31-3/4" (81.2cm)	21-1/2" (54.6cm)	21-1/2" (54.6cm)	7-5/8" (19.3cm)	24-1/2" X 30-1/4" (62.2 X 76.8cm)	16.7 amps. - 2KW - 120V 14.4 amps. - 3KW - 208V 12.5 amps. - 3KW - 240V	6.2 amps. - 120V - 1/4 HP	236 (107kg)
RM-HP-3	3	19-7/8" X 39-3/8" X 12-1/4" (50.4 X 99.9 X 31.1cm)	45-1/2" (116.2cm)	21-1/2" (54.6cm)	21-1/2" (54.6cm)	7-5/8" (19.3cm)	24-1/2" X 44" (62.2 X 111.7cm)	16.7 amps. - 2KW - 120V 14.5 amps. - 3KW - 208V 12.5 amps. - 3KW - 240V	6.2 amps. - 120V - 1/4 HP	267 (121.1kg)
RM-HP-4	4	19-7/8" X 53-1/8" X 12-1/4" (50.4 X 134.1 X 31.1cm)	59-1/8" (151.1cm)	21-1/2" (54.6cm)	21-1/2" (54.6cm)	7-5/8" (19.3cm)	24-1/2" X 57-3/4" (62.2 X 146.6cm)	14.4 amps. - 3KW - 208V 12.5 amps. - 3KW - 240V 19.3 amps. - 4KW - 208V 16.7 amps. - 4KW - 240V	6.5 amps. - 120V - 1/3 HP	305 (138.3kg)
RM-HP-5	5	19-7/8" X 66-7/8" X 12-1/4" (50.4 X 169.8 X 31.1cm)	73" (186cm)	21-1/2" (54.6cm)	21-1/2" (54.6cm)	7-5/8" (19.3cm)	24-1/2" X 71-1/2" (62.2 X 181.6cm)	19.3 amps. - 4KW - 208V 16.7 amps. - 4KW - 240V	10.7 amps. - 120V - 3/4 HP	342 (155.1kg)
RM-HP-6	6	19-7/8" X 80-5/8" X 12-1/4" (50.4 X 204.7 X 31.1cm)	86-3/4" (220.9cm)	21-1/2" (54.6cm)	21-1/2" (54.6cm)	7-5/8" (19.3cm)	24-1/2" X 85-1/4" (62.2 X 216.5cm)	19.3 amps. - 4KW - 208V 16.7 amps. - 4KW - 240V	10.7 amps. - 120V - 3/4 HP	423 (191.8kg)

*Units are wired to prevent simultaneous operation in the hot and cold mode. .

REFRIGERATION CHART							
MODEL	HP	REF.	OZ	LOW PSIG.	HIGH PSIG.	BTU M10 90A	TEMPERATURE SETTING / DIFFERENTIAL
RM-HP-1	1/5	R513A	12	6	175	450	8 OFF / 8 DIFF (16 ON)
RM-HP-2	1/4	R448A	17	30	275	624	3 OFF / 8 DIFF (11 ON)
RM-HP-3	1/4	R448A	19	30	275	624	3 OFF / 8 DIFF (11 ON)
RM-HP-4	1/3	R448A	22	30	275	865	3 OFF / 8 DIFF (11 ON)
RM-HP-5	3/4	R448A	27	30	275	N/A	3 OFF / 8 DIFF (11 ON)
RM-HP-6	3/4	R448A	30	30	275	N/A	3 OFF / 8 DIFF (11 ON)

REMOTE REFRIGERATION MODEL	RMHP-X LESS COMP. WT. (LBS.)
RMHP-X-1	101 (45.8kg)
RMHP-X-2	181 (82.10kg)
RMHP-X-3	190 (86.18kg)
RMHP-X-4	228 (103.41kg)
RMHP-X-5	265 (120.20kg)
RMHP-X-6	346 (1kg)

NOTERMHP-X REQUIRED A SOLENOID PACKAGE AND RSHP - REMOTE CONTROL PANEL

REFRIGERATED COLD PAN WITHOUT COMPRESSOR REQUIRED:

SOLENOID PACKAGE, LOOSE: SOLENOID VALVE, SOLENOID COIL & COOPER FITTING

SOLENOID PACKAGE, FACTORY INSTALLED: SOLENOID BOX, SOLENOID VALVE, COIL & COOPER FITTING

****ORDERS NOT FINAL UNTIL REFRIGERANT APPROVED****

COMPRESSORS FOR REMOTE INSTALLATIONS

- 2029-1M7 - 1/5 HP for RM-HPX-1
- 2029-11M6 - 1/4 HP for RM-HPX-2 & 3
- 2029-16M6 - 1/3 HP for RM-HPX-4
- 2029-13M6 - 1/2 HP for RM-HPX-5 & 6