



ATLAS METAL

1135 N.W. 159th DRIVE, MIAMI, FLORIDA 33169

TEL 305.625.2451

TOLL FREE 800.762.7565

FAX 305.623.0475

WWW.ATLASFOODSERV.COM

SALES@ATLASFOODSERV.COM

Project: _____

Item No.: _____

Quantity: _____

SLIDE-IN SERVING EQUIPMENT

REFRIGERATED BASE

RB-4

Self-Contained
Solid Top,
Under-Counter

RB-5



RB-4

SPECIFICATIONS

BODY: Double wall constructed with a 20 gauge, type 304 stainless steel interior liner, with coved corners. Exterior wall is 22 gauge galvanized steel, with an 18 gauge stainless steel fascia. The body is filled with 1" of high density polystyrene insulation on all sides. The interior of the body is provided with a removable slide assembly to accommodate 12" x 20" pans. A 2-1/2" dial thermometer is mounted in the fascia.

DOORS: Doors are double wall constructed of 18 gauge, type 304 stainless steel, fully insulated with high density polyurethane and provided with edge mounted, chrome plated hinges and a slam action latch. Doors are complete with a moisture-proof gasket.

REFRIGERATION SYSTEM: The compressor housing is integral with the body of the unit and provided with a removable, louvered access panel. A fully self-contained condensing unit is provided, with a hermetically sealed compressor and a thermostat control. The system is also provided with a forced air evaporator, for even temperature throughout the base, which drains into a condensate evaporator, pre-wired in the unit. The system is fully charged with CFC free refrigerant and ready to operate, factory set, between 35 and 45 degrees.

NOTE: Proper ventilation must be provided in counter

ELECTRICAL: The unit will be wired for 15 amp., 120 volt, single phase operation. A 6' long, 3-wire cord and plug (NEMA 5-15P) will be provided.

Specifications subject to change without notice.

STANDARD FEATURES

- Slides into your counter - puts refrigeration where you need it
- Fully insulated for maximum efficiency
- Slide assembly for standard 12" x 20" pans
- Self-contained refrigeration
- 1-Year Parts & Labor Warranty
- NSF Certified and UL Listed

ACCESSORIES

- **5YW** - 5-Year Compressor Warranty
- 18" x 26" Pan Rack (available on RB-4 only)

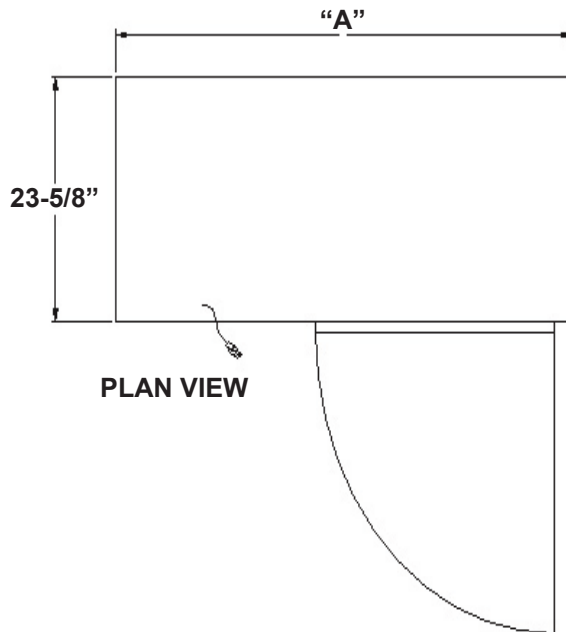

PLAN VIEW

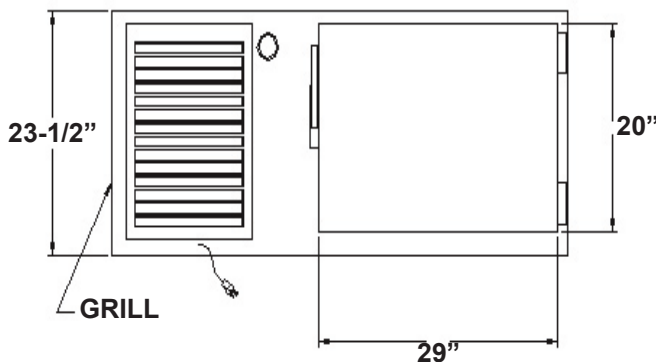

FRONT ELEVATION

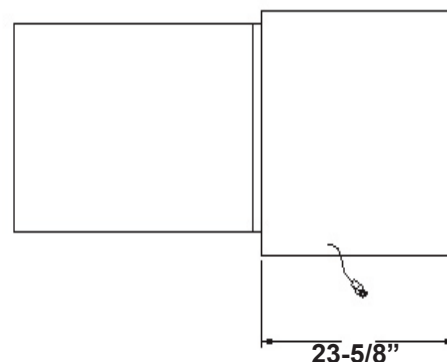

END VIEW

| MODEL | CUT-OUT REQUIRED | "A" | STORAGE CAPACITY 12" X 20" PANS | ELECTRICAL CHARACTERISTICS | SHIP WT. (LBS.) |
|-------|---------------------------------------|----------------------|------------------------------------|-------------------------------|--------------------|
| RB-4 | 23-5/8" X 55-5/8" (59.6 X 140.9cm) | 55-5/8" (140.9cm) | 10 Pans - 1 Door - 8 cu. ft. | 6.9 amps. - 120V 1/4 HP | 270 (122.4kg) |
| RB-5 | 23-5/8" X 69-1/2" (59.6 X 175.8cm) | 69-1/2" (175.8cm) | 15 Pans - 2 Doors - 10 cu. ft. | 6.9 amps. - 120V 1/4 HP | 340 (154.2kg) |

| REFRIGERATION CHART | | | | | | | |
|---------------------|-----|-------|-----|--------------|---------------|----------------|---------------------------------------|
| MODEL | HP | REF. | OZ. | LOW PSIG. | HIGH PSIG. | BTU M10 90A | TEMPERATURE SETTING / DIFFERENTIAL |
| RB-4 | 1/4 | R513A | 8 | 12 | 160 | 2940 | 32 OFF / 8DIFF |
| RB-5 | 1/4 | R513A | 9 | 12 | 160 | 2940 | 32 OFF / 6DIFF |