



# ATLAS METAL

1135 N.W. 159th DRIVE, MIAMI, FLORIDA 33169

TEL 305.625.2451

TOLL FREE 800.762.7565

FAX 305.623.0475

WWW.ATLASFOODSERV.COM

SALES@ATLASFOODSERV.COM

Project: \_\_\_\_\_

Item No.: \_\_\_\_\_

Quantity: \_\_\_\_\_

## SELF LEVELING DISPENSERS



MCT-1014

# TRAY DISPENSER

## Mobile Cantilever Tray Dispenser

- MCT-1014
- MCT-1216
- MCT-1418
- MCT-1520
- MCT-1622

### SPECIFICATIONS

The construction of the model MCT consists of a stainless steel exterior base, top and cabinet housing, all welded. The base shall be heavily reinforced with support channels for added strength.

**HANDLE:** Shall be 1" O.D. stainless steel

**TRAY CARRIER:** The cantilever tray platform shall be constructed of grade 18-8 stainless steel.

**SELF LEVELING:** Dispensing height shall be adjustable by adding or removing extension springs located behind the removable access panel of grade 18-8 stainless steel. The cantilevered platform shall be self leveling with heavy duty bearing and bearing guides.

**CORNER BUMPERS:** Shall be gray non-marking vinyl attached securely to the base.

**CASTERS:** Shall be 4" swivel heavy duty with optional brake.

*Specifications subject to change without notice.*

### STANDARD FEATURES

- Tray capacity approx. 100 to 150 trays per stack
- All stainless steel construction
- Tray capacities vary with the size and type if trays used
- Total load capacity: 250LBS
- NSF Approved

### ACCESSORIES

- Modify height
- **LB** - Locking brakes (set of 2)
- **WB** - Wrap around bumpers
- Silverware dispenser
  - SD-6** - 6 hole - with nylon cylinders
  - SD-8** - 8 hole - with nylon cylinders
  - SD-10** - 10 hole with nylon cylinders
- **ND** - Napkin dispenser

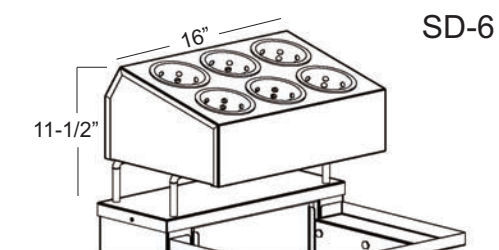

SD-6

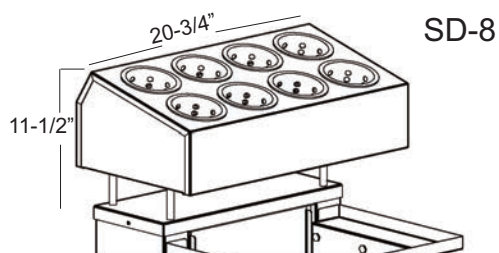

SD-8

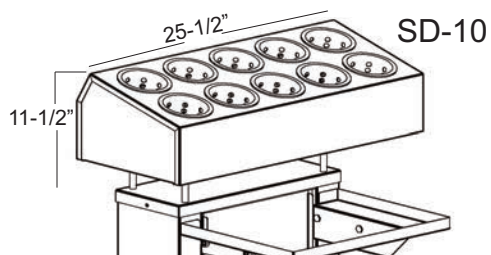

SD-10

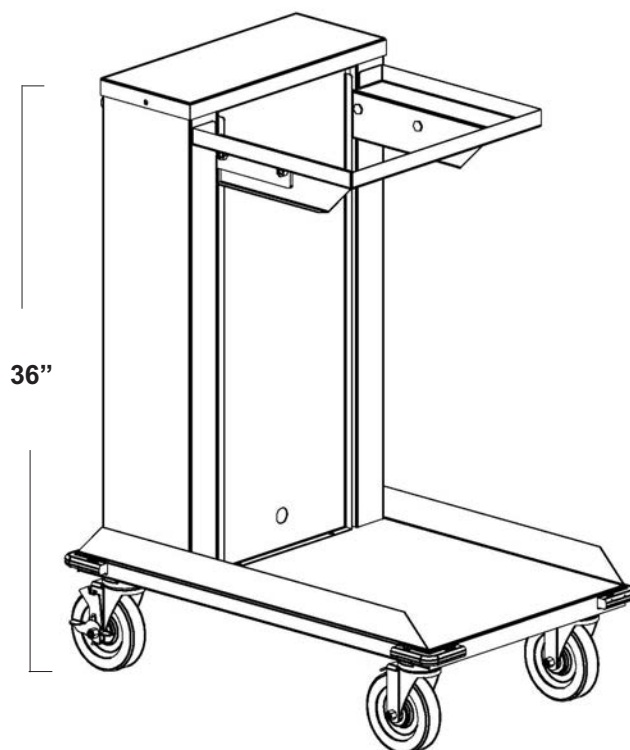

36"

**MCT: MOBILE CANTILEVER TRAY/DISPENSER**

MODEL	MAXIMUM TRAY SIZE	L X W	SHIPPING WT. (lbs.)
MCT-1014	10-7/8" X 15" (27.6 X 38.1cm)	22" X 17" (55.9 X 43.2cm)	108 (49kg)
MCT-1216	12-5/8" X 16-3/8" (32.1 X 41.6cm)	22" X 17" (55.9 X 43.2cm)	109 (49.4kg)
MCT-1418	14-5/8" X 18-3/8" (37.1 X 46.7cm)	28" X 17" (71.1 X 43.2cm)	112 (50.8kg)
MCT-1520	15-5/8" X 20-3/8" (39.7 X 51.7cm)	30" X 17" (76.2 X 43.2cm)	115 (52.2kg)
MCT-1622	16-5/8" X 22-3/8" (42.2 X 56.8cm)	32" X 17" (81.3 X 43.2cm)	123 (55.8kg)