



ATLAS METAL

MOBILE CANTILEVER
TRAY AND RACK
DISPENSERS

MODELS: MCT FOR TRAYS
MCR FOR RACKS

OPERATION, INSTALLATION AND MAINTENANCE MANUAL

MODEL MCT & MODEL MCR

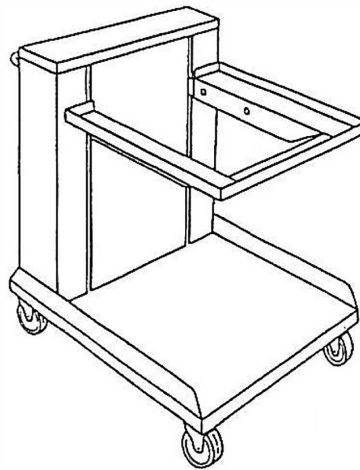

Total Load Capacity: 250 Pounds

WARNING! INSPECT UNIT THOROUGHLY FOR ANY DAMAGE THAT MAY HAVE OCCURRED DURING SHIPMENT BEFORE LOADING

OPERATION:

Load items on carrier tray, "DO NOT DROP" check to see if items fit on carrier tray with no more than 1" of side play. When fully loaded, push down on load and slowly release to allow load to set at proper dispensing height.

WARNING! NEVER REMOVE SPRINGS WHEN EXTENDED:

- (1) Personal injury can result if spring fully disengages from dispenser.
- (2) Damage to spring can result.

OPERATION/SPRING ADJUSTMENT:

The MCT & MCR models are shipped with field adjustable springs to accommodate various weight ranges up to 250 lbs. The unit is equipped with extension springs that can be engaged or disengaged from the carriage assembly for self leveling adjustment. Self leveling adjustment is achieved by removing the s/s access panel in front of the unit to the spring compartment where spring adjustments can be made.

INSTALLATION:

The open construction and mobility of the dispenser offers easy access, in a tray make up area or serving line, for many dispensing needs.

MOBILE CANTILEVER TRAY AND RACK DISPENSERS

MODELS: MCT FOR TRAYS
MCR FOR RACKS

GENERAL INFORMATION

TROUBLE SHOOTING:

Load uneven upon return

Check carriage assembly and springs for debris

Unit won't roll

Inspect wheels for damage

Possible debris on axle

Clean or replace as necessary

DISPENSING PROBLEMS PERSIST . . .

PUT DISPENSER OUT OF SERVICE! CALL FACTORY FOR SERVICE AUTHORIZATION. USE LICENSED QUALIFIED SERVICE PERSONNEL ONLY!

CLEANING INSTRUCTIONS:

TO CLEAN, WIPE DISPENSER THOROUGHLY WITH DAMP CLOTH AND MILD SOAP SUITABLE FOR USE IN FOOD CONTRACT ZONES. "NO ABRASIVES."

PARTS LIST

CONTACT FACTORY FOR PART NUMBERS AND PRICING. HAVE MODEL NUMBER AVAILABLE.

DESCRIPTION

Extension Springs

Carrier Tray

Casters

Casters w/Brake

SPECIFICATIONS

SELF-LEVELING MECHANISM:

Dispensing height shall be field adjustable by adding or deleting extension springs located behind the removable front access panel. The cantilevered self-leveling platform shall be constructed of grade 18-8 stainless steel. The self-leveling mechanism shall have large diameter heavy duty bearings and extra heavy duty bearing guides, to assure a long lasting, smooth operating dispenser.

CABINET AND BASE:

Cabinet housing, base top exterior, and self-leveling platform shall be constructed of heavy gauge, grade 18-8 stainless steel. The base shall be heavily reinforced with support channels. All dispensers shall be furnished with 4" diameter, non-marking heavy duty swivel casters (bolt on type) and gray non-marking corner bumpers.

NOTE: A stainless steel push handle shall be provided.

TRAY DISPENSERS MODEL MCT

MODEL	MAXIMUM WEIGHT	L & W	SHIPPING WEIGHT
MCT-1014	10 7/8" X 15"	22" X 17"	96 LBS.
MCT-1216	12 5/8" X 16 3/8"	22" X 17"	96 LBS.
MCT-1418	14 5/8" X 18 3/8"	28" X 17"	116 LBS.
MCT-1520	15 5/8" X 20 3/8"	30" X 17"	140 LBS.
MCT-1622	16 5/8" X 22 3/8"	32" X 17"	147 LBS.

RACK DISPENSERS MODEL MCT

MODEL	MAXIMUM WEIGHT	L & W	SHIPPING WEIGHT
MCR-1020	10 1/4" X 20 1/4"	20" X 21"	121 LBS.
MCR-2020	20 1/4" X 20 1/4"	30" X 21"	172 LBS.