



# ATLAS METAL

1135 N.W. 159th DRIVE, MIAMI, FLORIDA 33169

TEL 305.625.2451

TOLL FREE 800.762.7565

FAX 305.623.0475

WWW.ATLASFOODSERV.COM

SALES@ATLASFOODSERV.COM

Project: \_\_\_\_\_

Item No.: \_\_\_\_\_

Quantity: \_\_\_\_\_

## SELF LEVELING DISPENSERS



MCR-2020

# RACK DISPENSER

Mobile Cantilever  
Rack Dispenser

MCR-1020

MCR-2020

### SPECIFICATIONS

The construction of the model MCR consists of a stainless steel exterior base, top and cabinet housing, all welded. The base shall be heavily reinforced with support channels for added strength.

**HANDLE:** Shall be 1" O.D. stainless steel.

**TRAY CARRIER:** The cantilever tray platform shall be constructed of grade 18-8 stainless steel.

**SELF LEVELING:** Dispensing height shall be adjustable by adding or removing extension springs located behind the removable access panel of grade 18-8 stainless steel. The cantilevered platform shall be self leveling with heavy duty bearings and bearing guides.

**CORNER BUMPERS:** Shall be gray non-marking vinyl attached securely to the base.

**CASTERS:** Shall be 4" swivel heavy duty with optional brake.

*Specifications subject to change without notice.*

### STANDARD FEATURES

- Rack capacities vary with the size and types of racks used.
- All stainless steel construction
- Total load capacity: 250 LBS
- NSF Approved

### ACCESSORIES

- **LB** - Locking brakes (set of 2)
- **WB** - Wrap around bumpers

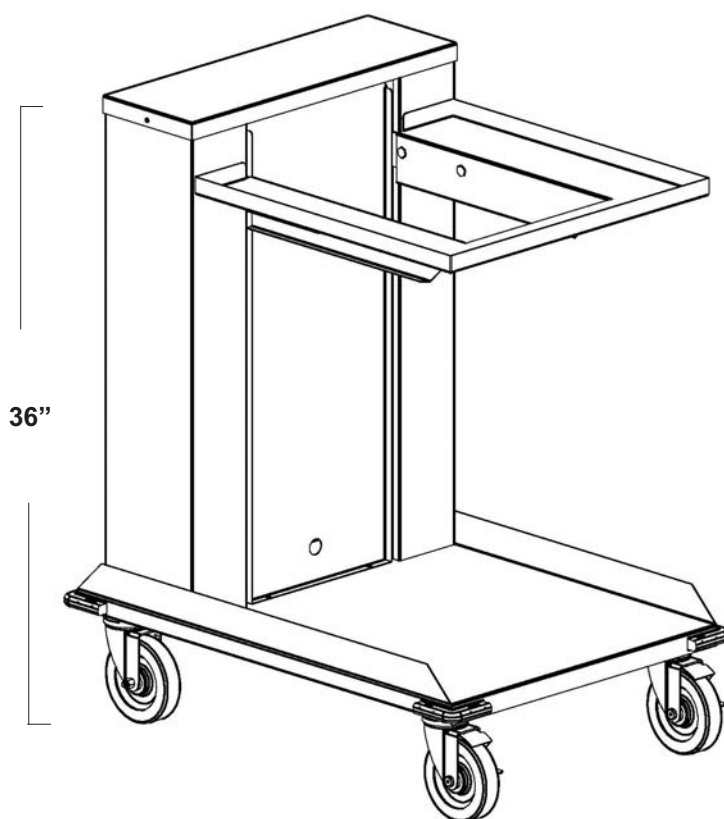

**MCR: MOBILE CANTILEVER RACK/DISPENSER**

<b>MODEL</b>	<b>MAXIMUM RACK SIZE</b>	<b>L X W</b>	<b>SHIPPING WT. (lbs.)</b>
MCR-1020	10-1/4" X 20-1/4" (26 X 51.4cm)	20" X 21" (50.8 X 53.3cm)	110 (49.9kg)
MCR-2020	20-1/4" X 20-1/4" (51.4 X 51.4cm)	30" X 21" (76.2 X 53.3cm)	123 (55.8kg)