



ATLAS METAL

1135 N.W. 159th DRIVE, MIAMI, FLORIDA 33169

TEL 305.625.2451

TOLL FREE 800.762.7565

FAX 305.623.0475

WWW.ATLASFOODSERV.COM

SALES@ATLASFOODSERV.COM

Project: _____
Item No.: _____
Quantity: _____

MODULAR UNITS CA SERIES



CWTS SHOWN WITH ACCESSORIES

TRAY DISPENSER

High Capacity

CWTS

SPECIFICATIONS

BODY: Frame construction shall be of hi-tensile stainless steel square tubing, 1-1/4" x 1-1/4". Frame sections are all welded construction, ground and polished to a uniform finish.

BOTTOM SHELF: Constructed of 18 gauge, type 304 stainless steel, welded, ground and polished to a uniform finish.

SILVER DISPENSER: Constructed of 16 gauge, type 304 stainless steel, welded, ground and polished to a uniform finish. Top section to be sloped forward and provided with ten (10 ea.) 4" dia. die-stamped openings.

CASTERS: The casters shall be 5" diameter, non-marking rubber tired, swivel type with ball bearings in both swivel and axle raceways, provided with grease fittings. Both casters on operator's side have toe activated brakes.

Specifications subject to change without notice.

STANDARD FEATURES

- High capacity tray storage - holds up to 200 trays
- Convenient silverware service
- Fully mobile - each unit is provided with 5" dia. swivel casters, two with brakes
- 1-Year Parts & Labor Warranty
- UL Listed

ACCESSORIES

- PCYL - Nylon silverware cylinders (10 required)
- Plastic Laminate Trim on Silverware Dispenser

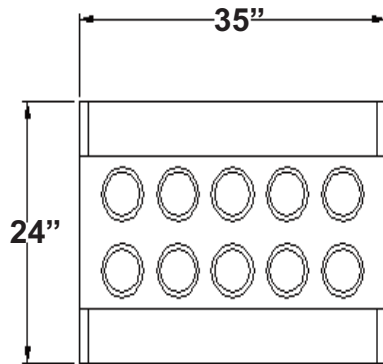

PLAN VIEW

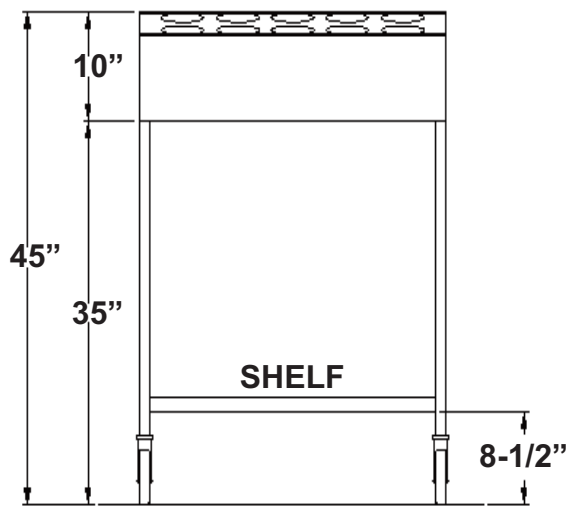

FRONT ELEVATION

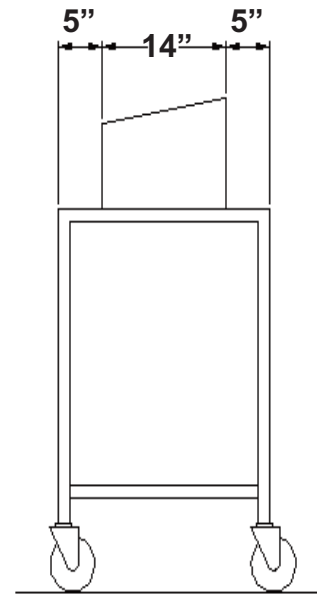

END VIEW

MODEL	SHIP WT. (lbs.)
CWTS	250 (113.3kg)