



ATLAS METAL

1135 N.W. 159th DRIVE, MIAMI, FLORIDA 33169

TEL 305.625.2451

TOLL FREE 800.762.7565

FAX 305.623.0475

WWW.ATLASFOODSERV.COM

SALES@ATLASFOODSERV.COM

Project: _____

Item No.: _____

Quantity: _____

MODULAR UNITS CA SERIES



CAU-4 SHOWN WITH ACCESSORIES

BEVERAGE UNIT

Single or Dual
Urn Drain

CAU-2

CAU-3

CAU-4

CAU-5

SPECIFICATIONS

TOP: Constructed of 16 gauge, type 304 stainless steel, die-formed, welded, ground and polished. An integral locking device shall be provided to align and retain cart positioning when two or more carts are joined.

BODY: Frame construction shall be of hi-tensile aluminum square tubing, 1-1/4" x 1-1/4". Frame sections are welded construction, ground and polished to a uniform finish. Body is complete with front panel and 7" rear apron of plastic laminate on .063 aluminum. Owner to specify finish.

URN TROUGH: The cart is includes a WU built-in urn drain installed in the top. Constructed of 18 gauge, type 304 stainless steel, with raised perimeter bead and solid vinyl gasket. The urn drain is formed in the top, 4-1/2" wide x 1-3/4" deep, with 1/4" minimum coved corners. The trough is provided with a removable, die-stamped anti-splash grate. A 3/4" dia. drain with strainer, 4" PVC nipple, and valve is provided.

CASTERS: The casters shall be 5" diameter, non-marking rubber tired, swivel type with ball bearings in both swivel and axle raceways, provided with grease fittings. Both casters on operator's side have toe activated brakes.

Specifications subject to change without notice.

STANDARD FEATURES

- Anti-splash grate - removable for ease in cleaning
- Positive self-locking device - keeps tops level and equipment in place
- Fully mobile - each unit is provided with 5" dia. swivel casters, two with brakes
- Versatile - available in a wide range of sizes and a wide variety of finishes and colors
- 1-Year Parts & Labor Warranty

ACCESSORIES

- **SL** - Tray Slide, 11-1/4" wide, S/S, 2-rail, fold down
- **SLT** - Tray Slide, 11-1/4" wide, S/S, 3-rail, fold down
- **SLS** - Tray Slide, 11-1/4" wide, S/S, solid, ribbed, fold down
- **SLF** - Tray Slide, 11-1/4" wide, plastic laminate with S/S runners, fold down
- **SH** - Work Shelf, 8" wide, S/S, fold down
- **CB** - Work Shelf, 8" wide, hardwood maple, fold down
- **CR** - Work Shelf, 8" wide, Richlite, fold down
- **ES** - End Shelf, 16" wide, S/S, fold down
- **CBE** - End Shelf, 16" wide, hardwood maple, fold down
- **EPA** - End Panel, aluminum w/ plastic laminate (each)
- **S** - S/S front panel
- **EPS** - S/S End Panel (each)
- **PP** - Painted Panels, urethane, in lieu of laminate
- **US** - Undershelf, S/S, removable
- **RPS** - Rear sliding doors, removable
- **HD** - Hinged Door, S/S
- **DL** - Door Locks (set)(for **RPS** or **HD**)
- **SC** - Square cutout
- **RC** - Round cutout
- **RST** - Reinforced S/S Top
- **CO** - Convenience outlet - specify voltage and amperage
- **CO-DUP** - Convenience Outlet, Duplex receptacle
- **JBC** - Outlet Box in base, 4x4 (120V) with cord
- **JBH** - Outlet Box in base, 4x4 (120V/240V) w/ cord
- **ERS** - Electrical Raceway System
- **PCS** - 7 to 10 ft. Power Cord
- **CW** - Cord Wrap
- **P-CAST** - Polyurethane Casters, 2-w/ Brakes
- **Legs** - with adjustable feet, in lieu of casters
- **BSF** - Front skirt with recessed casters
- **BSE** - End skirt
- **BSR** - Rear skirt
- Dual service urn drain with anti-splash grate (**CAU** becomes **CAUD**)(contact factory)

CA-3

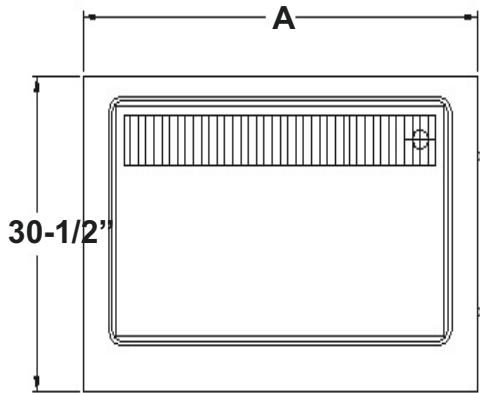

PLAN VIEW

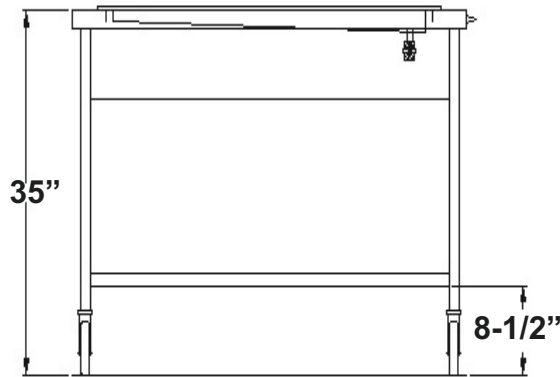

REAR ELEVATION

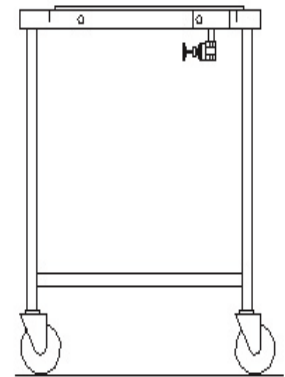

END VIEW

MODEL	"A"	URN DRAIN DIMENSION	SHIP WT. (LBS)
CAU-2	36-1/4" (92cm)	4-1/2" X 25-11/16" (11.43cm X 63.5cm)	150 (68cm)
CAU-3	50" (127cm)	4-1/2" X 39-7/16" (11.43cm X 99.06cm)	180 (81.6cm)
CAU-4	63-3/4" (161.9cm)	4-1/2" X 53-3/16" (11.43cm 134.62X cm)	220 (99.8cm)
CAU-5	77-1/2" (231.7cm)	4-1/2" X 66-15/16" (11.43cm X 167.64cm)	270 (122.5cm)