



TEL 305.625.2451

ATLAS METAL

1135 N.W. 159th DRIVE, MIAMI, FLORIDA 33169

TOLL FREE 800.762.7565

FAX 305.623.0475

CAIH SERIES

Service and Installation Manual

Please read this manual completely before attempting to install or operate this equipment!
Notify carrier of damage! Inspect all components immediately. See page 1.



Effective Date: 2020
IMPORTANT INFORMATION
READ BEFORE USE

CONTENTS

RECEIVING & INSPECTING EQUIPMENT.....	1
SERIAL AND MODEL NUMBER LOCATION.....	1
CAIH SPECIFICATIONS, FEATURES AND ACCESSORIES.....	2-3
WIH SPECIFICATIONS, FEATURES AND ACCESSORIES.....	4-5
WIHL SPECIFICATIONS, FEATURES AND ACCESSORIES.....	6-7
INSTALLATION, OPERATION AND S/S MAINTENANCE.....	8
ELECTRICAL CHARACTERISTICS AND CUT-OUT REQUIREMENTS.....	9
REMOTE CONTROL INSTALLATION.....	9
PARTS LIST.....	10
AUTOMATIC WATER FILL INSTALLATION, OPERATION & PARTS DIAGRAM.....	11
TROUBLE SHOOTING GUIDE.....	12
ELECTRICAL SCHEMATICS 120v.....	13
ELECTRICAL SCHEMATICS 208v - 240v.....	14
LIMITED WARRANTY.....	15
WARRANTY INFORMATION.....	16

RECEIVING AND INSPECTING THE EQUIPMENT

1. VISUALLY INSPECT THE SHIPPING CRATE. DAMAGE SHOULD BE NOTED AND REPORTED TO THE DELIVERING CARRIER.
2. IF DAMAGED, OPEN AND INSPECT CONTENTS WITH CARRIER.
3. IF CRATE IS NOT DAMAGED AND THERE IS CONCEALED DAMAGE TO THE EQUIPMENT, NOTIFY THE CARRIER. NOTIFICATION MUST BE MADE VERBALLY AND IN WRITING.
4. REQUEST AN INSPECTION BY THE SHIPPING COMPANY FOR THE DAMAGED EQUIPMENT WITHIN 10 DAYS FROM RECEIPT OF THE EQUIPMENT
5. FREIGHT CARRIERS CAN SUPPLY THE NECESSARY FORMS ON REQUEST.
6. SAVE ALL CRATING MATERIALS UNTIL INSPECTION HAS BEEN MADE OR WAIVED.

SERIAL NUMBER LOCATION

THE SERIAL AND MODEL# CAN BE FOUND ON THE OPERATORS CONTROL PANEL. WHEN CALLING ATLAS FOR PARTS AND SERVICE ALWAYS HAVE THIS INFORMATION AVAILABLE.

SERIAL #: _____

MODEL #: _____

INSTALLATION DATE: _____



ATLAS METAL

1135 N.W. 159th DRIVE, MIAMI, FLORIDA 33169

TEL 305.625.2451

TOLL FREE 800.762.7565

FAX 305.623.0475

WWW.ATLASFOODSERV.COM

SALES@ATLASFOODSERV.COM

Project: _____
Item No.: _____
Quantity: _____

MODULAR UNITS CA SERIES



CAIH-5 SHOWN WITH ACCESSORIES

HOT FOOD UNIT

Electrically Heated
Individual Controls
Optional Drain & Manifold

- CAIH-2
- CAIH-3
- CAIH-4
- CAIH-5
- CAIH-6

SPECIFICATIONS

TOP: Constructed of 16 gauge, type 304 stainless steel, die-formed, welded, ground and polished. The top is provided with an opening to receive the appropriately sized drop-in unit. An integral locking device shall be provided to align and retain cart positioning when two or more carts are joined.

BODY: Frame construction shall be of hi-tensile aluminum square tubing, 1-1/4" x 1-1/4". Frame sections are welded construction, ground and polished to a uniform finish. Body is complete with front panel and 7" rear apron of plastic laminate on .050 aluminum. Owner to specify finish.

HOT FOOD PAN: The cart includes a WIH series drop-in hot pan installed in the top. Constructed of 18 gauge, type 304 stainless steel, with a raised perimeter bead and solid vinyl gasket. Individual 12" x 20" hot food wells are provided, fabricated of 18 gauge stainless steel, one piece construction, all welded, ground and polished to a uniform finish. All corners are covered with a minimum 1/4" radius. The pan is fully insulated with high density fiberglass insulation, 1" thick on all sides, 2" thick on the bottom and enclosed with a 22 gauge galvanized steel outer case

ELECTRICAL: The unit is provided with 850 watt heating elements, pre-wired to individual thermostat controls, with a pilot light for each well. A 6' long, 3-wire cord and plug is provided, extending from the control box located under the unit, on operator's left. Bottom of outer case can be removed for access to electrical components.

CASTERS: The casters shall be 5" diameter, non-marking rubber tired, swivel type with ball bearings in both swivel and axle raceways, provided with grease fittings. Both casters on operator's side have toe activated brakes.

Specifications subject to change without notice.

STANDARD FEATURES

- Fully insulated to retain heat - individual, thermostatically controlled 12" x 20" hot food wells
- Positive self-locking device - keeps tops level and equipment in place
- Fully mobile - each unit is provided with 5" dia. swivel casters, two with brakes
- Versatile - available in a wide range of sizes and a wide variety of finishes and colors
- Wet or Dry Operation
- 1-Year Parts & Labor Warranty
- NSF Approved, UL Listed

ACCESSORIES

- **SL** - Tray Slide, 11-1/4" wide, S/S, 2-rail, fold-down
- **SLT** - Tray Slide, 11-1/4" wide, S/S, 3-rail, fold-down
- **SLS** - Tray Slide, 11-1/4" wide, S/S, solid, ribbed, fold-down
- **SLF** - Tray Slide, 11-1/4" wide, plastic laminate with S/S runners, fold-down
- **SH** - Work Shelf, 8" wide, S/S, fold-down
- **CB** - Work Shelf, 8" wide, hardwood maple, fold-down
- **CR** - Work Shelf, 8" wide, Richlite, fold-down
- **ES** - End Shelf, 16" wide, S/S, fold-down
- **CBE** - End Shelf, 16" wide, hardwood maple, fold-down
- **EPA** - End Panel, aluminum w/ plastic laminate (each)
- **S** - S/S Front Panel
- **EPS** - S/S End Panel (each)
- **PP** - Painted Panels, urethane, in lieu of laminate
- **US** - Undershelf, S/S, removable
- **RPS** - Rear Sliding Doors, removable
- **HD** - Hinged Doors, S/S
- **DL** - Door Locks (set)(for **RPS** or **HD**)
- **Sneeze Guards** - various styles available (see sneeze guard section of catalog)
- **RC** - Round Cutout
- **CO** - Convenience Outlet (specify base or apron mount)
- **CO-DUP** - Convenience Outlet, Duplex receptacle
- **JBH** - Outlet Box in base, 4x4 (120V/240V) with cord
- **ERS** - Electrical Raceway System
- **PCS** - 7 to 10 ft. Power Cord
- **CW** - Cord Wrap
- **P-CAST** - Polyurethane Casters, 2-W/Brakes
- **Legs** with adjustable feet, in lieu of casters
- **BSF** - Front Skirt with recessed casters
- **BSE** - End Skirt (each)
- **BSR** - Rear Skirt
- **Stainless Steel Adapter Plates & Adapter Bars** (pgs. DI-51 - DI-52)
- **CP** - Cover Plate with handles, S/S
- **D** - Individual Drain and Valve for each well (3/4" dia. drain)
- **DM** - Individual Drain for each well with manifold to single valve
- **DMV** - Individual Drain with valve for each well with manifold to single valve
- **DME** - Individual drain for each well with manifold to single valve w/ reat ext.
- **RDVE** - Rear Drain valve extension for **DM** & **DMV** (1) required
- **AMC** - Apron mounted remote controls
- **MS** - Master on/off switch
- **AF** - Automatic water fill

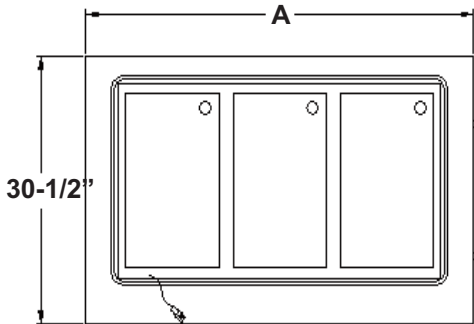

PLAN VIEW

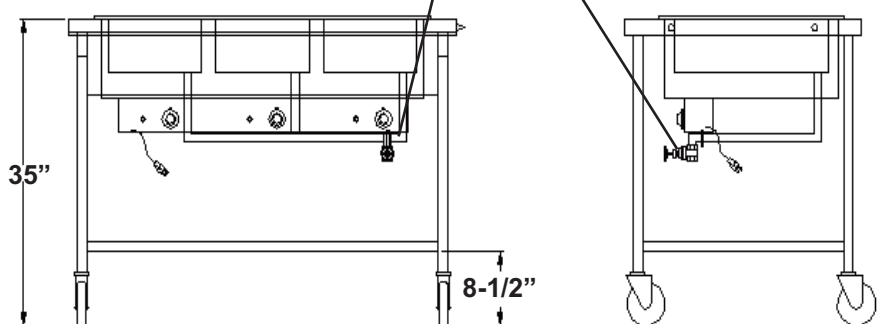

REAR ELEVATION

END VIEW

Electrical Characteristics

MODEL	WATTAGE	VOLTAGE/KW/AMPS	NEMA # PLUG
CAIH-2	850WATT	120V - 1.7KW - 14.2	5-20P
		208V - 1.7KW - 8.2	6-15P
		240V - 1.7KW - 7.1	6-15P
	1000WATT	120V - 2.0KW - 16.7	6-30P
		208V - 2.0KW - 9.6	6-15P
		240V - 2.0KW - 8.3	6-15P
CAIH-3	850WATT	120V - 2.55KW - 21.3	5-30P
		208V - 2.55KW - 12.3	L6-20P
		240V - 2.55KW - 10.6	6-15P
	1000WATT	120V - 3.0KW - 25.0	5-50P
		208V - 3.0KW - 14.4	L6-20P
		240V - 3.0KW - 12.5	L6-20P
CAIH-4	850WATT	208V - 3.4KW - 16.4	L6-30P
		240V - 3.4KW - 14.2	L6-20P
	1000WATT	208V - 4.0KW - 19.2	L6-30P
		240V - 4.0KW - 16.7	L6-30P
CAIH-5	850WATT	208V - 4.25KW - 20.4	L6-30P
		240V - 4.25KW - 17.7	L6-30P
	1000WATT	208V - 5.0KW - 24.0	L6-30P
		240V - 5.0KW - 20.8	L6-30P
CAIH-6	850WATT	208V - 5.1KW - 24.5	6-50P
		240V - 5.1KW - 21.3	L6-30P
	1000WATT	208V - 6.0KW - 28.8	6-50P
		240V - 6.0KW - 25.0	6-50P

MODEL	"A"	FOOD WELLS	SHIP WT. (LBS)
CAIH-2	36-1/4" (92cm)	2	165 (74.8kg)
CAIH-3	50" (127cm)	3	200 (90.7kg)
CAIH-4	63-3/4" (161.9cm)	4	250 (113.4kg)
CAIH-5	77-1/2" (196.8cm)	5	305 (138.3kg)
CAIH-6	91-1/4" (231.7cm)	6	355 (161kg)



ATLAS METAL

1135 N.W. 159th DRIVE, MIAMI, FLORIDA 33169

TEL 305.625.2451

TOLL FREE 800.762.7565

FAX 305.623.0475

WWW.ATLASFOODSERV.COM

SALES@ATLASFOODSERV.COM

Project: _____

Item No.: _____

Quantity: _____

DROP-IN SERVING EQUIPMENT



WIH-3

HOT PAN
Electrically Heated
Individual Controls

- WIH-1**
- WIH-2**
- WIH-3**
- WIH-4**
- WIH-5**
- WIH-6**

SPECIFICATIONS

TOP: Constructed of 18 gauge, type 304 stainless steel, die stamped with a raised perimeter bead. There shall be a solid vinyl gasket under the beaded edge to form a seal to the counter top, thus preventing seepage or marring of the counter top.

HOT FOOD WELLS: Individual hot food wells shall be 18 gauge, type 304 stainless steel, one piece construction, all welded, ground and polished to a uniform finish. All corners are covered with a minimum 1/4" radius. Each well is provided with an 850 watt heating element (1000 watt on the WIH-1).

INSULATION: The pan is fully insulated with high density fiberglass, 1" thick on all sides, 2" thick on the bottom and enclosed with a 22 gauge galvanized steel outer case.

ELECTRICAL: The unit is provided with an individual thermostat control with a pilot light for each well. All heating elements and controls are pre-wired, and a 6' long, 3-wire cord and plug is provided, extending from the control box located under the unit, on operator's left. Bottom of outer case can be removed for access to electrical components.

Specifications subject to change without notice.

STANDARD FEATURES

- Fully insulated to retain heat - protects fixtures and saves energy
- Individual thermostat controls - the operator can control the temperature of each well separately
- Factory applied gasket - makes installation a snap and seals units to the counter, thus eliminating seepage
- Accommodates standard 12"x20" pans, or fractional size pans with the use of optional adapter bars
- Wet or Dry Operation
- 1-Year Parts & Labor Warranty
- UL Listed, ETL Listed

ACCESSORIES

- Stainless steel adapter bars (pg DI-51-52)
- Stainless steel adapter plates (pg DI-51-52)
- **CP** - Cover Plate with handles, S/S
- **D** - Individual Drain and Valve for each well (3/4" dia. drain)
- **DM** - Individual Drain for each well with manifold to single valve
- **DMV** - Individual Drain with valve for each well with manifold to single valve
- **DME** - Individual drain for each well with manifold to single valve w/ rear extension
- **RDVE** - Rear Extension for **D**, **DM**, & **DMV** (1) required
- **RT** - Remote Thermostats for counter installation, 36" long
- **RTL** - Remote Thermostats for counter installation, 72" long
- **MS** - Master on/off switch
- **AF** - Automatic water fill (NOTE: **DM** required for water fill)

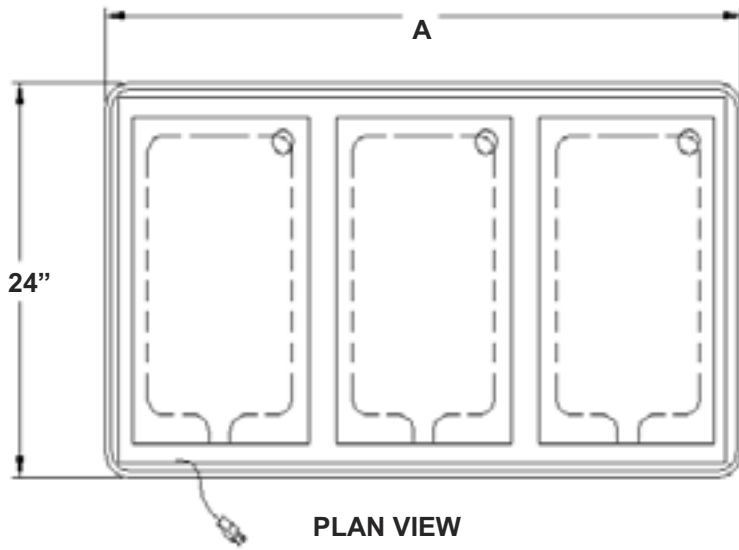

CONFORMS TO
NSF STD 4
NSF STD 2

SHOWN WITH OPTIONAL DME -
DRAIN AND MANIFOLD WITH
REAR EXTENSION

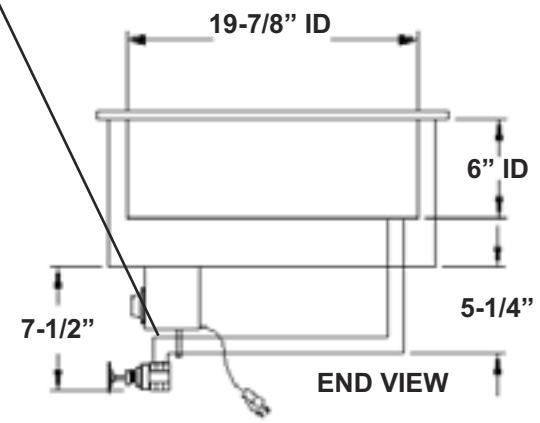
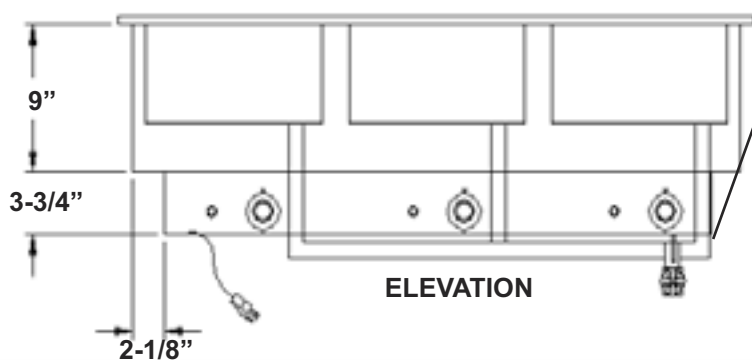

Electrical Characteristics

MODEL	WATTAGE	VOLTAGE/KW/AMPS	NEMA # PLUG
WIH-1	1000WATT	120V - 1.0KW - 8.3 208V - 1.0KW - 4.8 240V - 1.0KW - 4.2	5-15P 6-15P 6-15P
WIH-2	850WATT	120V - 1.7KW - 14.2 208V - 1.7KW - 8.2 240V - 1.7KW - 7.1	5-20P 6-15P 6-15P
	1000WATT	120V - 2.0KW - 16.7 208V - 2.0KW - 9.6 240V - 2.0KW - 8.3	L5-30P 6-15P 6-15P
WIH-3	850WATT	120V - 2.55KW - 21.3 208V - 2.55KW - 12.3 240V - 2.55KW - 10.6	L5-30P L6-20P 6-15P
	1000WATT	120V - 3.0KW - 25.0 208V - 3.0KW - 14.4 240V - 3.0KW - 12.5	5-50P L6-20P L6-20P
WIH-4	850WATT	208V - 3.4KW - 16.4 240V - 3.4KW - 14.2	L6-30P L6-20P
	1000WATT	208V - 4.0KW - 19.2 240V - 4.0KW - 16.7	L6-30P L6-30P
WIH-5	850WATT	208V - 4.25KW - 20.4 240V - 4.25KW - 17.7	L6-30P L6-30P
	1000WATT	208V - 5.0KW - 24.0 240V - 5.0KW - 20.8	L6-30P L6-30P
WIH-6	850WATT	208V - 5.1KW - 24.5 240V - 5.1KW - 21.3	6-50P L6-30P
	1000WATT	208V - 6.0KW - 28.8 240V - 6.0KW - 25.0	6-50P 6-50P

MODEL	"A"	COUNTER CUT-OUT (REQUIRED) W X L	CONTROL PANEL CUT-OUT (IF REQUIRED)	SHIP WT. (LBS.)
WIH-1	16" (40.6cm)	22-1/4" X 14-1/4" (56.5 X 36.8cm)	4-1/2" X 6-1/4" (11.4 X 15.8cm)	41 (18.5kg)
WIH-2	29-3/4" (75.5cm)	22-1/4" X 28" (56.5 X 71.1cm)	4-1/2" X 12-1/4" (11.4 X 31.1cm)	112 (50.8kg)
WIH-3	43-1/2" (110.4cm)	22-1/4" X 41-3/4" (56.5 X 111.1cm)	4-1/2" X 26" (11.4 X 66cm)	152 (68.9kg)
WIH-4	57-1/4" (145.4cm)	22-1/4" X 55-1/2" (56.5 X 140.9cm)	4-1/2" X 39-3/4" (11.4 X 100.9cm)	188 (85.3kg)
WIH-5	71" (180.3cm)	22-1/4" X 69-1/4" (56.5 X 175.8cm)	4-1/2" X 53-1/2" (11.4 X 135.8cm)	225 (102kg)
WIH-6	84-3/4" (213.3cm)	22-1/4" X 83" (56.5 X 210.8cm)	4-1/2" X 67-1/4" (11.4 X 170.8cm)	268 (121.5kg)

Note: Numeral following the model letters denotes the 12X20 pan capacity



ATLAS METAL

1135 N.W. 159th DRIVE, MIAMI, FLORIDA 33169

TEL 305.625.2451

TOLL FREE 800.762.7565

FAX 305.623.0475

WWW.ATLASFOODSERV.COM

SALES@ATLASFOODSERV.COM

Project: _____

Item No.: _____

Quantity: _____

SLIM-LINE DROP-IN SERVING EQUIPMENT



SLIM-LINE HOT PAN

Electrically Heated Individual Controls

WIHL-2

WIHL-3

WIHL-4

SPECIFICATIONS

TOP: Constructed of 18 gauge, type 304 stainless steel, die stamped with a raised perimeter bead. There shall be a solid vinyl gasket under the beaded edge to form a seal to the counter top, thus preventing seepage or marring of the counter top.

HOT FOOD WELLS: Individual hot food wells shall be 18 gauge, type 304 stainless steel, one piece construction, all welded, ground and polished to a uniform finish. All corners are covered with a minimum 1/4" radius. Each well is provided with an 850 watt heating element.

INSULATION: The pan is fully insulated with high density fiberglass insulation, 1" thick on all sides, 2" thick on the bottom, and enclosed by a 22 gauge galvanized steel outer case.

ELECTRICAL: The unit is provided with an individual thermostat control and pilot light for each well. All heating elements and controls are pre-wired, and a 6' long, 3-wire cord and plug is provided, extending from the control box located under the unit, on operator's left. Bottom of outer case can be removed for access to electrical components.

Specifications subject to change without notice.

STANDARD FEATURES

- Slim line configuration - it can install in counters only 16" wide
- Fully insulated to retain heat - protects fixtures and saves energy
- Individual thermostat controls - the operator can control the temperature of each well separately
- Factory applied gasket - makes installation a snap and seals units to the counter top, thus eliminating seepage
- Accommodates standard 12" X 20" pans, or fractional size pans with the use of optional adapter bars.
- Wet or Dry Operation
- 1-Year Parts & Labor Warranty
- UL Listed, ETL Listed

ACCESSORIES

- Stainless steel adapter bars (pg DI-51-52)
- Stainless steel adapter plates (pg DI-51-52)
- CPL - Cover Plate with handles, S/S
- D - Individual Drain and Valve for each well (3/4" dia. drain)
- DM - Individual Drain for each well with manifold to single valve
- DMV - Individual Drain with valve for each well with manifold to single valve
- DME - Individual drain for each well with manifold to single valve w/ rear extension
- RDVE - Rear Extension for D, DM, DMV & DME (1) required
- RT - Remote Thermostats for counter installation, 36" long
- RTL - Remote Thermostats for counter installation, 72" long
- MS - Master on/off switch
- AF - Automatic water fill (NOTE: DM required for water fill)

*Please see Operation & Installation Manual for ALL operation and maintenance details.



**CONFORMS TO
NSF STD 4
NSF STD 2**

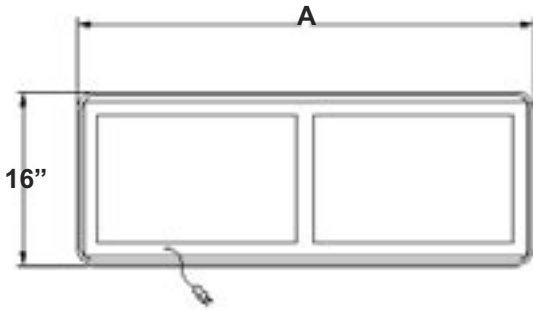

PLAN VIEW

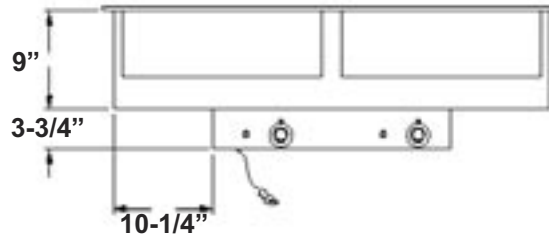

ELEVATION

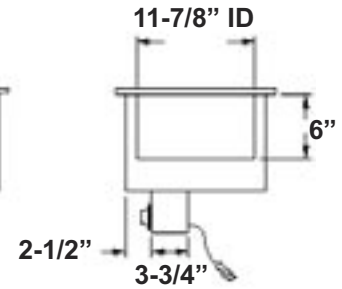

END VIEW

Electrical Characteristics

MODEL	WATTAGE	VOLTAGE/KW/AMPS	NEMA # PLUG
WIHL-2	850WATT	120V - 1.7KW - 14.2	5-20P
		208V - 1.7KW - 8.2	6-15P
		240V - 1.7 KW - 7.1	6-15P
	1000WATT	120V - 2.0KW - 16.7	5-30P
		208V - 2.0KW - 9.6	6-15P
		240V - 2.0KW - 8.3	6-15P
WIHL-3	850WATT	120V - 2.55KW - 21.3	5-30P
		208V - 2.55KW - 12.3	L6-20P
		240V - 2.55KW - 10.6	6-15P
	1000WATT	120V - 3.0KW - 25.0	5-50P
		208V - 3.0KW - 14.4	L6-20P
		240V - 3.0KW - 12.5	L6-20P
WIHL-4	850WATT	208V - 3.4KW - 16.4	L6-30P
		240V - 3.4KW - 14.2	L6-20P
	1000WATT	208V - 4.0KW - 19.2	L6-30P
		240V - 4.0KW - 16.7	L6-30P

MODEL	"A"	COUNTER CUT-OUT (REQUIRED) W X L	CONTROL PANEL CUT-OUT (IF REQUIRED)	SHIP WT. (LBS.)
WIHL-2	46" (116.8cm)	14-1/4" X 44-1/4" (36.8 X 113.6cm)	4-1/2" X 12-1/4" (11.4 X 31.1cm)	118 (53.5kg)
WIHL-3	67-3/4" (172cm)	14-1/4" X 66" (36.8 X 167.6cm)	4-1/2" X 26" (11.4 X 66cm)	176 (79.8kg)
WIHL-4	89-1/2" (227.3cm)	14-1/4" X 87-3/4" (36.8 X 222.8cm)	4-1/2" X 39-3/4" (11.4 X 100.9cm)	210 (95.2kg)

Note: Numeral following the model letters denotes the 12X20 pan capacity

WH/WIH/WIHL

INSTALLATION

Provide the correct counter cut-out opening and drop in. The vinyl gasket assures complete seating. A non-toxic silicone seal may be used between the gasket and counter top (not required). The unit is supplied with a power cord and NEMA plug. Refer to the data plate on the control panel for the amperage and voltage information. Use a licensed electrician when installing power source.

* Control box on 14 1/4" side.

OPERATION

During operation the unit must be used with water and the thermostat must be set at position #10. The thermostat dial has an off position and is numbered 1 to 10 (Number 10 is the highest and mandatory setting for operation).

MAINTENANCE

NEVER CLEAN PANS WITH A CHLORIDE BASED PRODUCT. CHLORIDES OR IMPROPER CLEANING COULD SCAR, MARK AND/OR CORRODE PANS. **DO NOT** USE STEEL WOOL OR ABRASIVE PRODUCTS. TO CLEAN USE SOAPY WARM WATER, RINSE THOROUGHLY TO REMOVE ALL RESIDUES. **FAILURE TO MEET THESE CONDITIONS WILL VOID WARRANTY.**



ATLAS METAL

Subsidiary of Mercury Aircraft, Inc.

1135 N.W. 159th DR., MIAMI, FL 33169
 PHONE (305) 625-2451, (800) 762-7565, FAX (305) 623-0475, E-mail: sales@atlasfoodserv.com

WH/WIH STANDARD INSTALLATION

WIH-REMOTE INSTALLATION

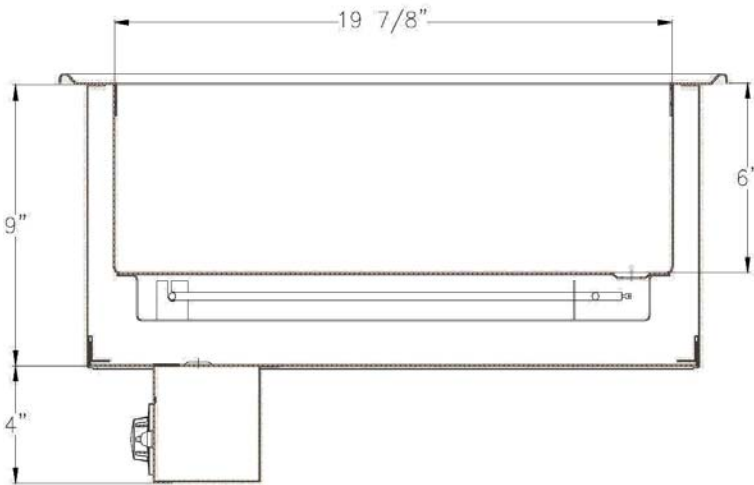

SIDE SECTIONAL VIEW

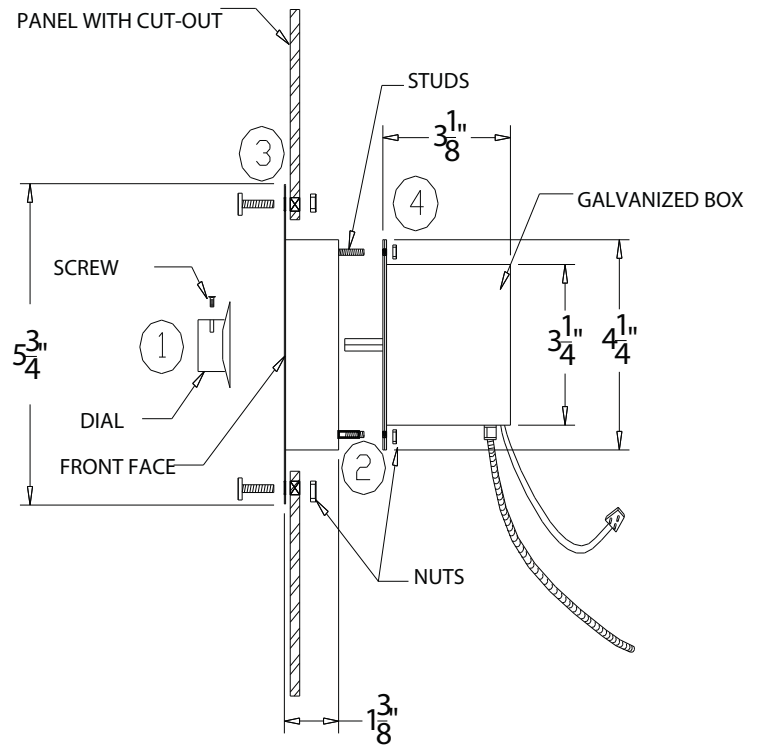

INSTALLATION OF THE REMOTE CONTROL HOT UNITS

Provide the correct Cut-Out opening for the remote control panel (see chart below).
 Remove control box from the bottom of the unit.

- 1) Remove black control dial from front of control panel by loosening screws.
- 2) Remove 6/32 fiber nuts from the back of the control box.
- 3) Mount the S/S front plate to the Cut-Out in apron.
- 4) Attach the galvanized box to the S/S front plate.

The unit is ready to be connected to the electrical receptacle. Refer to the data plate on the control panel for the amperage and voltage information. Use a licensed electrician when installing power source.

MODEL	CUT-OUT SIZE
1	4 1/2 x 6 1/4
2	4 1/2 x 12 1/4
3	4 1/2 x 26
4	4 1/2 x 39 3/4
5	4 1/2 x 53 1/2
6	4 1/2 x 67 1/4

CAUTION: HANDLE CONTROL PANEL & CONDUIT CAREFULLY, THERMOSTAT CAPILLARY TUBE IS VERY FRAGILE, IF BROKEN, HEATING SYSTEM WILL NOT OPERATE.

FAILURE TO MEET THESE CONDITIONS WILL VOID WARRANTY.



ATLAS METAL

Subsidiary of Mercury Aircraft, Inc.

1135 N.W. 159th DR., MIAMI, FL 33169

PHONE (305) 625-2451, (800) 762-7565, FAX (305) 623-0475, E-mail: sales@atlasfoodserv.com

PARTS LIST ELECTRICAL HEATED UNITS
W/AUTOMATIC WATER FILL
WH/ WIHD&M/ WIHLD&M- /WIHD&M- 1-6 SERIES

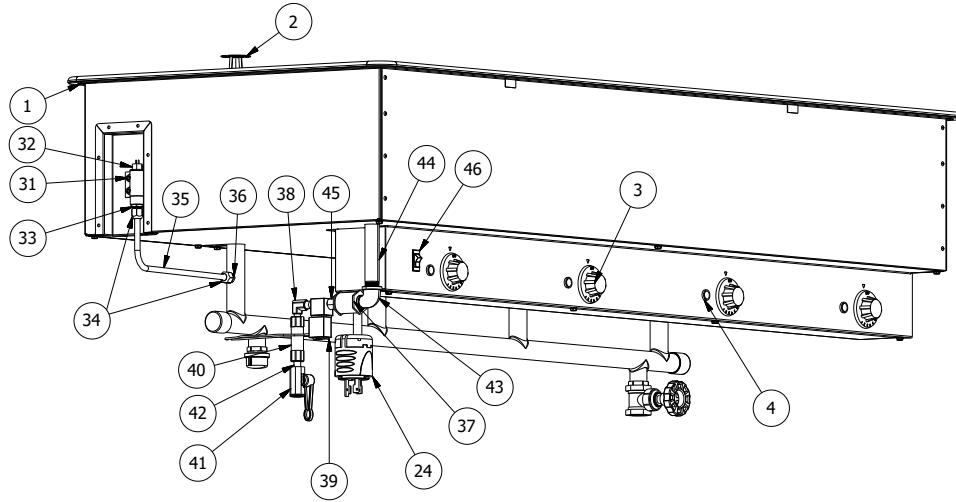

ITEM NUMBER	PART NUMBER	DESCRIPTION
1	7002-0+Model #	Vinyl Bead Gasket
2	86-3202	Perforated Snap in Drain
3	1097-2	Dial
4	1100	Pilot Light
5	3007-3	3/4" Brass Nipple 7" long
6	3016-11	Brass Gate Valve
7	1088-5	P-136 Terminal (#22 & 18 wire)
8	1089-2	P-151 Terminal (#10 & 12 wire)
9	1089-4	P-144 Terminal (#14 & 16 wire)
10	1098	S Screw Thermostat Mounting
11	1096-60	Remote Thermostat with 48" Bulb
12	1096-96	Remote Thermostat with 72" Bulb
13	1012-100	12" Nickel Wire
14	1014-100	14" Nickel Wire
15	1096-36	Thermostat
16	S81113-2	Element Holder
17	SC0099-238	S/S Element Holder
18	1053-HT	120V-850W Element
19	1054-HT	208V-850W Element
20	1055-HT	240V-850W Element
21	1056-HT	120V-1000W Element
22	1057-HT	240V-1000W Element
23	1058-HT	208V-1000W Element
24	1002	Power Cord 14/3
	1004	Power Cord 12/3
	1004-4	Power Cord 10/3

ITEM NUMBER	PART NUMBER	DESCRIPTION
25	12-228	Plug 20Amp 240V
26	1022	Plug 30Amp 240V
27	12-256	Plug 30Amp 120V
28	1012-101	#12 Green Wire (Ground)
29	1014-101	#14 Green Wire (Ground)
30	1001-1	50 Amp Cord & Plug
31	48-22	S/S 10 x 1/2 Screws
32	S84553	Reservoir Assembly
33	51-25	1/4" x 3/8" NPT Male Conn.
34	2050	Brass Flare Nut
35	2031	1/4" Copper Tubing
36	21-23	1/4" x 1/4" Brass Union
37	600022-1	Dual check vacuum breaker #98d NPTM 1/4" (BACK FLOW PREVENTION)
38	30-46	90° Street Elbow
	1800-3904	Solenoid Valve 120V
39	1800-3903	Solenoid Valve 240V
40	600002	Brass In Line Strainer
41	1800-35	Ball In Valve
42	1800-39	Close Nipple
43	87-69	90° 1/2" to 1/4" Reducing Elbow Brass
44	87-70	1/2 dia. Brass Pipe Threaded Both Ends
45	87-68	1/8" Male to 1/4" female reducer
46	1069-1	Switch

AUTOMATIC WATER FILL UNITS

WIH, WH AND WCMHP/RMHP SERIES

INSTALLATION

When installing water supply to the unit, the supply lines must be purged to remove particles from damaging the solenoid valve operation. A factory supplied in-line water strainer is installed. However, it is recommended the customer supply a primary water filtering system for protection.

***Note-Atlas Metal Ind. Inc. is not responsible for routine maintenance of the strainer or customer supplied water filter system.**

***Atlas Metal Industries Inc. recommends that all units installed to a water source use our Autofill or any backflow protection of your choice. Please refer to your local code.**

Any attempt to change or modify the Auto Fill system will void the warranty.

OPERATION

To operate the Auto Fill system, turn the Auto-fill On/Off switch, located on the control panel, to the On position. Allow water to complete filling the pan to the water level mark before energizing the heating cycle.

***Note -** Factory water depth settings for A/F units are 1/4" for WIH, 1/2" for WH & WCMHP/RMHP are 1/2" above the heating element cover.

DO NOT manually add water to Auto-fill units above water level mark, damage and leakage to the Automatic sensor could result. As the water evaporates the pans will fill automatically. **It is recommended that the Auto Fill be in the off position when not in use.**

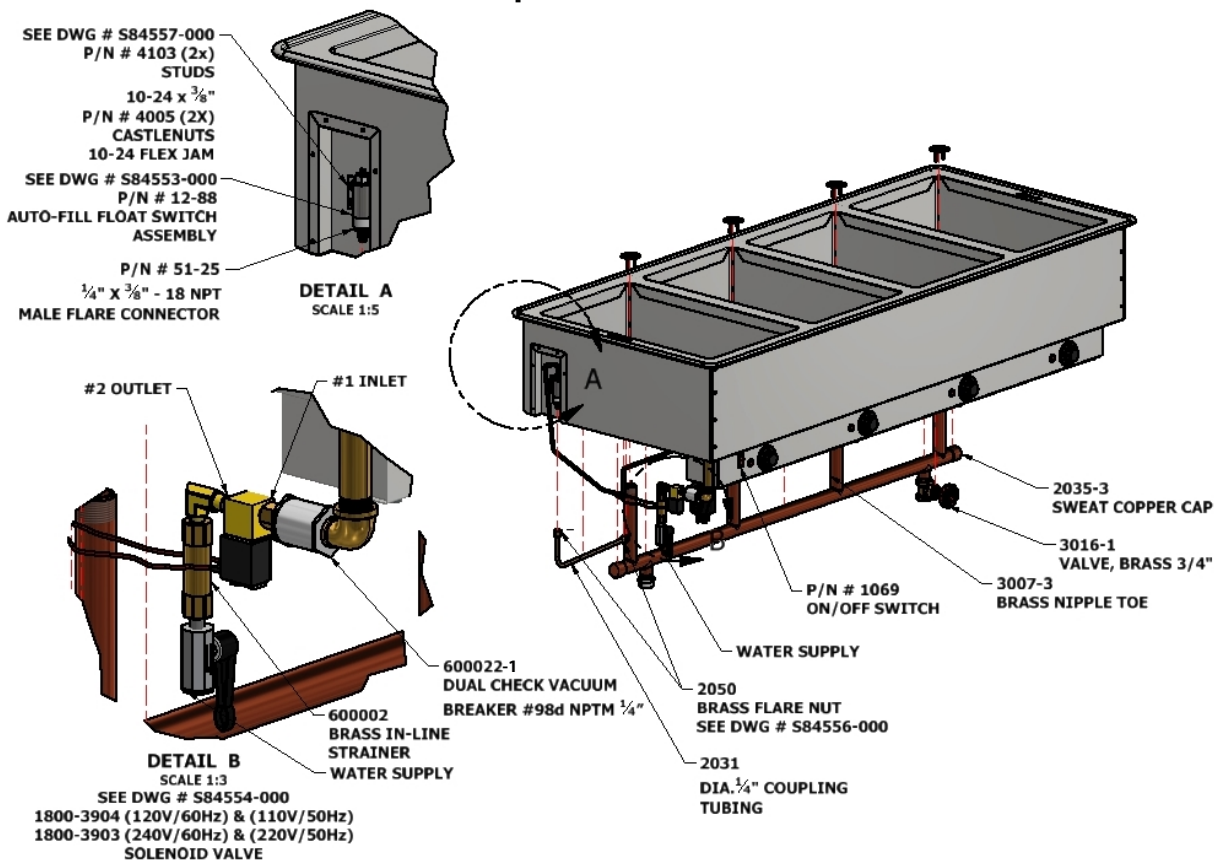



ATLAS METAL

Subsidiary of Mercury Aircraft, Inc.

1135 N.W. 159th DR., MIAMI, FL 33169

PHONE (305) 625-2451, (800) 762-7565, FAX (305) 623-0475, E-mail: sales@atlasfoodserv.com

Electric Hot Food Drop-In Trouble Shooting Guide

Symptom	Probable Cause
Unit will not heat	Unit not plugged in. No power at receptacle. Thermostat and or switch not in the on position. Call factory for service at 1-800-762-7565
Food products not hot enough.	Thermostat's not turned to the highest setting. Food products not hot enough when placed in unit. Food product not being stirred or rotated. Heat lamp or head strip over the food product is recommended. Call factory for service at 1-800-762-7565.
<p style="text-align: center;">NOTE: Before starting any warranty repair work you must first call the factory for authorization. Failure to do so can make you responsible for repair cost.</p>	

REVISION HISTORY		
REV	DESCRIPTION	DATE
1	CHANGE LABLES	2/16/2012

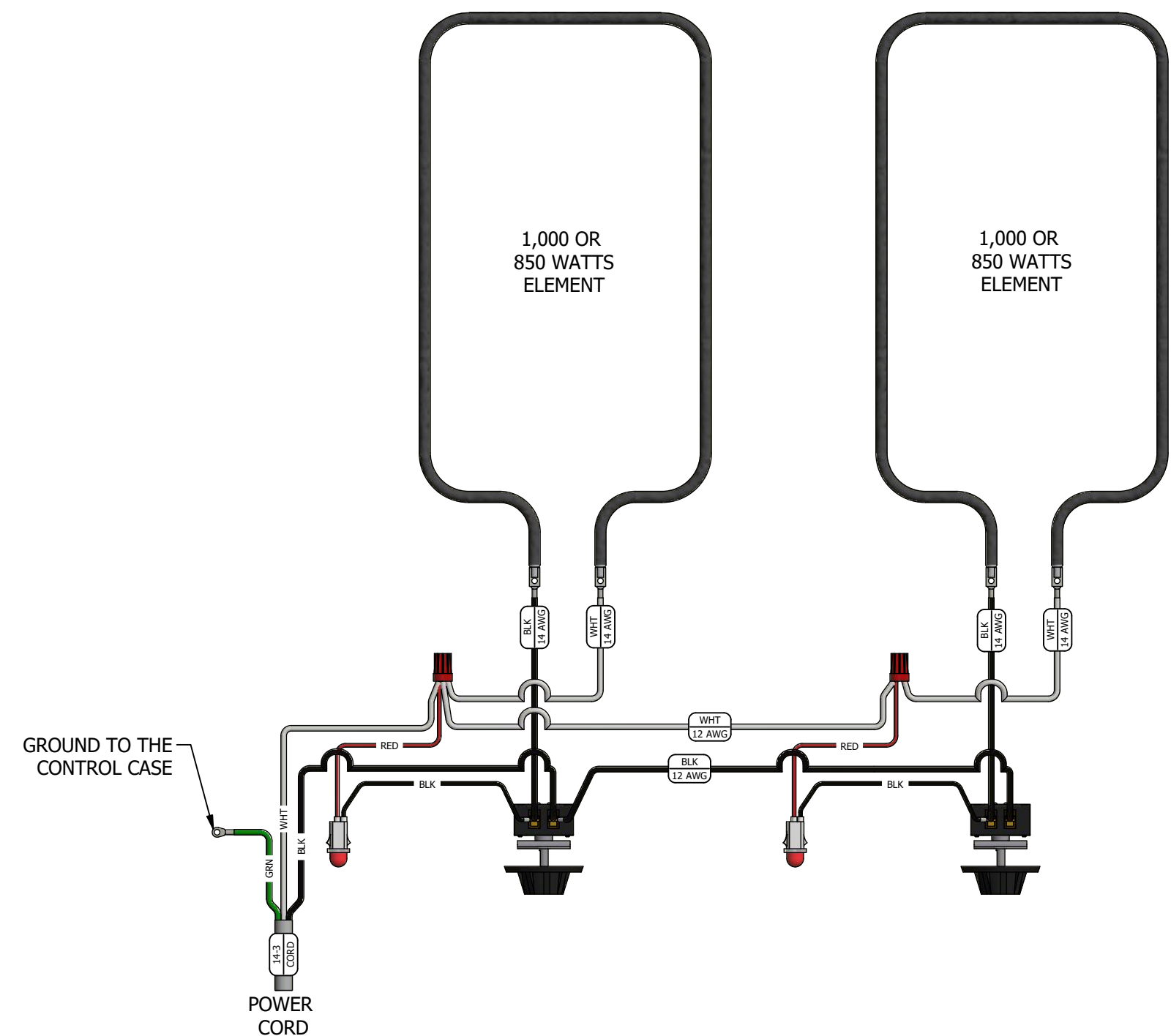

MATERIAL:		DRAWN BY: L.AND		DATE: 11/30/2010	 ATLAS METAL 1135 NW 159TH DRIVE MIAMI, FLORIDA 33169
CATEGORY: WIH	TOLERANCES	CHECKED BY: ----		DESCRIPTION: ELECTRICAL SCHEMATIC	
BREAK ALL SHARP CORNERS. PART TO BE FREE OF BURRS.	XXX DECIMAL ± 0.015 ANGULARITY ± 1° UNLESS SPECIFIED ON DRAWING	THIS SHEET CONTAINS CONFIDENTIAL INFORMATION, IMAGES AND TRADE SECRETS OF ATLAS METALS, INC. ANY UNAUTHORIZED USE OR DISCLOSURE OF ANY PORTION THEREOF IS STRICTLY PROHIBITED. THIS WORK IS THE EXCLUSIVE PROPERTY OF ATLAS METALS INDUSTRIES, INC. ALL RIGHTS RESERVED.		SIZE: B	PART NUMBER: WIH-2 120V
UNLESS OTHERWISE SPECIFIED, ALL DIMENSIONS ARE IN INCHES		SHEET No.	1 OF 1	SCALE: ----	

REVISION HISTORY		
REV	DESCRIPTION	DATE
1	CHANGE LABLES	2/16/2012

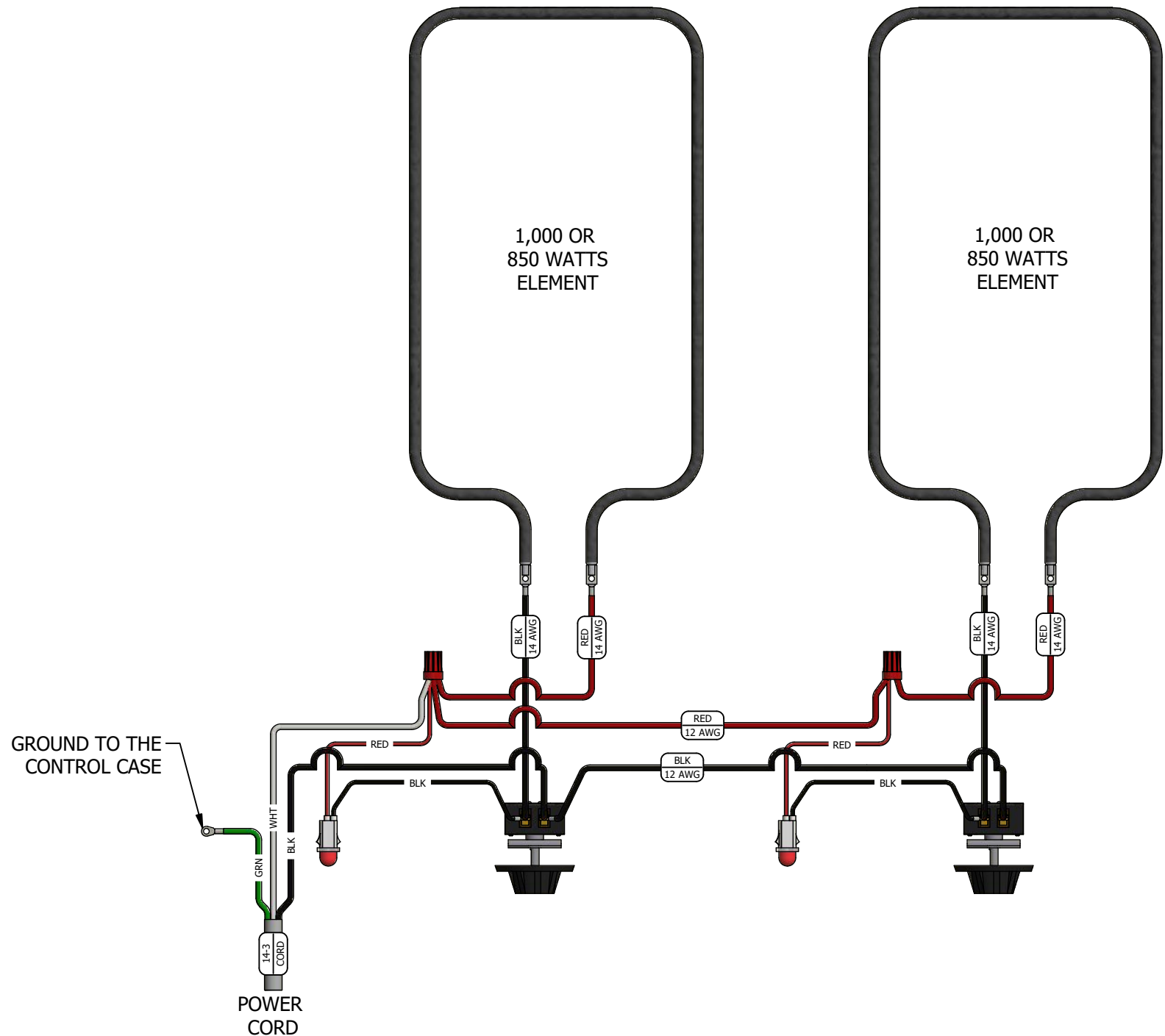

MATERIAL:			
CATEGORY:		DRAWN BY:	DATE:
WIH		L.AND	11/30/2010
	TOLERANCES	CHECKED BY: ----	
BREAK ALL SHARP CORNERS. PART TO BE FREE OF BURRS.	XXX DECIMAL ± 0.015	THIS SHEET CONTAINS CONFIDENTIAL INFORMATION, IMAGES AND TRADE SECRETS OF ATLAS METALS, INC. ANY UNAUTHORIZED USE OR DISCLOSURE OF ANY PORTION THEREOF IS STRICTLY PROHIBITED. THIS WORK IS THE EXCLUSIVE PROPERTY OF ATLAS METALS INDUSTRIES, INC. ALL RIGHTS RESERVED.	
UNLESS OTHERWISE SPECIFIED, ALL DIMENSIONS ARE IN INCHES	ANGULARITY ± 1° UNLESS SPECIFIED ON DRAWING		



ATLAS METAL
1135 NW 159TH DRIVE MIAMI, FLORIDA 33169

DESCRIPTION: ELECTRICAL SCHEMATIC	
SIZE: B	PART NUMBER: WIH-2 208-240V
SHEET No. 1 OF 1	SCALE: ----



A T L A S M E T A L

LIMITED WARRANTY

Atlas Metal Industries, Inc. warrants to the Purchaser of this product that the same shall be free from defects in the workmanship and material for a period of one year from the date of original installation of the equipment, but not to exceed eighteen (18) months after date of shipment from factory. During this period of time Atlas Metal Industries, Inc. will replace all defective parts and will pay for authorized replacement labor. Replacement and installation of such parts and labor shall be provided only upon prior written authority of Atlas Metal Industries, Inc.

The Refrigeration warranty is for a twenty (20) month time period and includes supplying the compressor at a no charge basis provided the damage to the compressor was not caused by the customer or end user. Authorized replacement labor will be paid for a period of one year from date of installation. Freight costs for defective unit to and from Atlas Metal Industries, Inc. are not included, and all defective parts must be returned to the factory freight prepaid for evaluation. **ALL WARRANTY LABOR MUST BE AUTHORIZED BY ATLAS METAL INDUSTRIES, INC. PRIOR TO THE ACTUAL WORK BEING DONE.** This warranty does not apply to any equipment or any part thereof, which has been subjected to shipping damage, improper voltage, alteration, abuse or misuses, and does not cover loss of food, other products, or damage to property due to mechanical or electrical malfunction.

THERE ARE NO WARRANTIES WHICH EXTEND BEYOND THE DESCRIPTION OF THE FACE HEREOF. SELLER DISCLAIMS ANY IMPLIED WARRANTY OF MERCHANTABILITY OF THE GOODS OR THE FITNESS OF THE GOODS FOR ANY PURPOSE AND BUYER AGREES THAT THE GOODS ARE SOLD "AS IS."



A T L A S M E T A L

WARRANTY INFORMATION

In order to have your invoice approved for payment by the factory, please note the following:

An authorization number must be obtained from the factory prior to performing any warranty service.

Atlas Metal will not approve excessive labor due to poor access to the unit being serviced. If design does not allow reasonable access, contact the factory.

All travel time that exceeds 100 miles round trip must be authorized by the factory.

**Thank You:
Warranty service Dept.**